Agilent 4285A Precision LCR Meter
Getting Started Guide

SERIAL NUMBERS

This manual applies directly to instruments with serial number prefix 3009J.



Agilent Part No. 04285-90011
Printed in JAPAN March 2001

Fourth Edition

Notice

The information contained in this document is subject to change without notice.

This document contains proprietary information which is protected by copyright. All rights are reserved. No part of this document may be photocopied, reproduced, or translated to another language without the prior written consent of the Agilent Technologies.

Agilent Technologies Japan, Ltd.
Component Test PGU-Kobe
1-3-2, Murotani, Nishi-ku, Kobe-shi,
Hyogo, 651-2241 Japan

Manual Printing History

The manual printing date and part number indicate its current edition. The printing date changes when a new edition is printed. (Minor corrections and updates which are incorporated at reprint do not cause the date to change.) The manual part number changes when extensive technical changes are incorporated.

June 1990 First Edition (part number: 04285-90001)
December 1996 Second Edition (part number: 04285-90011)
March 2000 Third Edition (part number: 04285-90011)
March 2001 Fourth Edition (part number: 04285-90011)

Safety Summary

The following general safety precautions must be observed during all phases of operation, service, and repair of this instrument. Failure to comply with these precautions or with specific *WARNINGS* elsewhere in this manual may impair the protection provided by the equipment. In addition it violates safety standards of design, manufacture, and intended use of the instrument.

The Agilent Technologies assumes no liability for the customer's failure to comply with these requirements.

Note



4285A complies with INSTALLATION CATEGORY II and POLLUTION DEGREE 2 in IEC1010-1.4285A is INDOOR USE product.

Note



LEDs in this product are Class 1 in accordance with IEC825-1.
CLASS 1 LED PRODUCT

Ground The Instrument

To avoid electric shock hazard, the instrument chassis and cabinet must be connected to a safety earth ground by the supplied power cable with earth blade.

DO NOT Operate In An Explosive Atmosphere

Do not operate the instrument in the presence of flammable gasses or fumes. Operation of any electrical instrument in such an environment constitutes a definite safety hazard.

Keep Away From Live Circuits

Operating personnel must not remove instrument covers. Component replacement and internal adjustments must be made by qualified maintenance personnel. Do not replace components with the power cable connected. Under certain conditions, dangerous voltages may exist even with the power cable removed. To avoid injuries, always disconnect power and discharge circuits before touching them.

DO NOT Service Or Adjust Alone

Do not attempt internal service or adjustment unless another person, capable of rendering first aid and resuscitation, is present.

DO NOT Substitute Parts Or Modify Instrument

Because of the danger of introducing additional hazards, do not install substitute parts or perform unauthorized modifications to the instrument. Return the instrument to a Agilent Technologies Sales and Service Office for service and repair to ensure that safety features are maintained.

Dangerous Procedure Warnings

Warnings , such as the example below, precede potentially dangerous procedures throughout this manual. Instructions contained in the warnings must be followed.

Warning



Dangerous voltages, capable of causing death, are present in this instrument. Use extreme caution when handling, testing, and adjusting this instrument.

Safety Symbols

General definitions of safety symbols used on equipment or in manuals are listed below.



Instruction manual symbol: the product is marked with this symbol when it is necessary for the user to refer to the instruction manual.



Alternating current.



Direct current.



On (Supply).



Off (Supply).



In position of push-button switch.



Out position of push-button switch.



Frame (or chassis) terminal. A connection to the frame (chassis) of the equipment which normally include all exposed metal structures.

Warning



This **Warning** sign denotes a hazard. It calls attention to a procedure, practice, condition or the like, which, if not correctly performed or adhered to, could result in injury or death to personnel.

Caution



This **Caution** sign denotes a hazard. It calls attention to a procedure, practice, condition or the like, which, if not correctly performed or adhered to, could result in damage to or destruction of part or all of the product.

Note



Note denotes important information. It calls attention to a procedure, practice, condition or the like, which is essential to highlight.



Affixed to product containing static sensitive devices use anti-static handling procedures to prevent electrostatic discharge damage to component.

4285A Precision LCR Meter Documentation Map

The documentation for the 4285A has been separated into several manuals. Following is a brief description of each manual and its purpose.

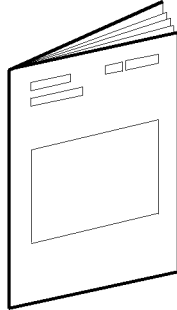

The *4285A Getting Started Guide* walks you through system setup and initial power-up, shows how to make basic measurements and explains commonly used features.

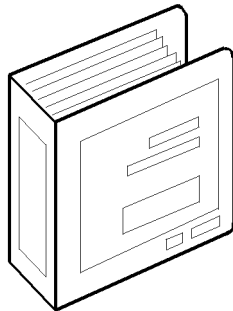

The *4285A OPERATION MANUAL* (Agilent Part Number 04285-90020) provides general information, specifications, GPIB programming information, and in depth reference information.

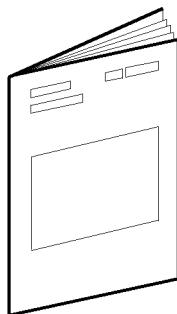

The *4285A MAINTENANCE MANUAL* (Agilent Part Number 04285-90030) explains how to verify conformance to published specifications.

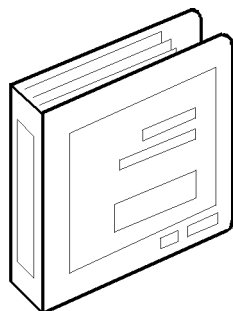

The *4285A SERVICE MANUAL* (Agilent Part Number 04285-90031) explains how to adjust, troubleshoot, and repair the instrument. (Furnished Option 915 only.)

Typeface Conventions

| | |
|-----------------|--|
| Bold | Boldface type is used when a term is defined. For example: icons are symbols. |
| <i>Italics</i> | Italic type is used for emphasis and for titles of manuals and other publications. Italic type is also used for keyboard entries when a name or a variable must be typed in place of the words in italics. For example: copy <i>filename</i> means to type the word copy, to type a space, and then to type the name of a file such as file1. |
| Computer | Computer font is used for on-screen prompts and messages. |
| HARDKEYS | Labeled keys on the instrument front panel are enclosed in □. |
| SOFTKEYS | Softkeys located to the right of the Liquid Crystal Display (LCD) are enclosed in ▣. |

Certification

Agilent Technologies certifies that this product met its published specifications at the time of shipment from the factory. Agilent Technologies further certifies that its calibration measurements are traceable to the United States National Institute of Standards and Technology (NIST), to the extent allowed by the Institute's calibration facility, or to the calibration facilities of other International Standards Organization members.

Warranty

This Agilent Technologies instrument product is warranted against defects in material and workmanship for a period of one year from the date of shipment, except that in the case of certain components listed in "Components not Covered by Warranty" in Chapter 1 of this manual, the warranty shall be for the specified period. During the warranty period, Agilent Technologies will, at its option, either repair or replace products which prove to be defective.

For warranty service or repair, this product must be returned to a service facility designated by Agilent Technologies. Buyer shall prepay shipping charges to Agilent Technologies and Agilent Technologies shall pay shipping charges to return the product to Buyer. However, Buyer shall pay all shipping charges, duties, and taxes for products returned to Agilent Technologies from another country.

Agilent Technologies warrants that its software and firmware designated by Agilent Technologies for use with an instrument will execute its programming instruction when properly installed on that instrument. Agilent Technologies does not warrant that the operation

of the instrument, or software, or firmware will be uninterrupted or error free.

Limitation of Warranty

The foregoing warranty shall not apply to defects resulting from improper or inadequate maintenance by Buyer, Buyer-supplied software or interfacing, unauthorized modification or misuse, operation outside of the environmental specifications for the product, or improper site preparation or maintenance.

No other warranty is expressed or implied. Agilent Technologies specifically disclaims the implied warranties of merchantability and fitness for a particular purpose.

Exclusive Remedies

The remedies provided herein are buyer's sole and exclusive remedies. Agilent Technologies shall not be liable for any direct, indirect, special, incidental, or consequential damages, whether based on contract, tort, or any other legal theory.

Assistance

Product maintenance agreements and other customer assistance agreements are available for Agilent Technologies products.

For any assistance, contact your nearest Agilent Technologies Sales and Service Office. Addresses are provided at the back of this manual.

Contents

| | |
|--|------|
| 1. Before You Begin | |
| Initial Considerations | 1-1 |
| Preparation for Use | 1-2 |
| Power Requirements | 1-2 |
| Line Voltage and Fuse Selection | 1-2 |
| Line Voltage Selection | 1-2 |
|  Fuse Selection | 1-2 |
| Setting Up the High Current DC Biased Measurement System | 1-3 |
| Equipment Required | 1-3 |
| Installing the Test Fixture | 1-3 |
| Interconnecting the Units | 1-4 |
| Setting Up the Precision Q Measurement System | 1-4 |
| Equipment Required | 1-4 |
| Interconnecting the Units | 1-4 |
| Connecting 4285A, 42841A, and 42851A | 1-5 |
| Equipment Required | 1-5 |
| Interconnecting Cables | 1-5 |
| 2. Getting Acquainted with the 4285A | |
| Front Panel Description | 2-1 |
| LCD Panel and Softkey | 2-1 |
| MENU keys and Display Pages | 2-2 |
| CURSOR and CURSOR Keys | 2-3 |
| ENTRY Keys | 2-4 |
| GPIB Status Indicator and LCL Key | 2-4 |
| TRIGGER Key | 2-4 |
| Memory Card Slot | 2-5 |
| DC-BIAS Key | 2-5 |
| Contrast Control Knob | 2-5 |
| Front Panel Operation | 2-6 |
| 3. Basic Measurement Examples | |
| Introduction | 3-1 |
| Capacitor Measurement | 3-1 |
| Measurement Conditions | 3-1 |
| Equipment Required | 3-1 |
| Operation Procedure | 3-1 |
| Inductance Measurements | 3-5 |
| Measurement Conditions | 3-5 |
| Equipment Required | 3-5 |
| Operation Procedure | 3-5 |
| DC Voltage Biased Measurement | 3-10 |
| Measurement Conditions | 3-10 |
| Equipment Required | 3-10 |

| | |
|---|------|
| Preparation Before Measurement | 3-10 |
| Checking the Option Installed | 3-10 |
| Operation Procedure | 3-10 |
| Measurements Using 1m/2m Test Leads | 3-14 |
| Equipment Required | 3-14 |
| Operation Procedure | 3-14 |
| DC Current Biased Measurement | 3-20 |
| Measurement Conditions | 3-20 |
| Equipment Required | 3-20 |
| Preparation Before Measurement | 3-20 |
| Checking the Option Installed | 3-20 |
| Configuring the High Current Biased Measurement System | 3-20 |
| Operation Procedure | 3-23 |
| Precision Q Measurement | 3-27 |
| Measurement Conditions | 3-27 |
| Equipment Required | 3-27 |
| Preparation Before Measurement | 3-27 |
| Checking the Option Installed | 3-27 |
| Configure the Precision Q measurement System | 3-27 |
| Operation Procedure | 3-28 |
| | |
| 4. Instrument Feature Tutorial | |
| Memory Function | 4-1 |
| System Memory | 4-1 |
| Internal Non-Volatile Memory/External Memory Card | 4-2 |
| Automatic Level Control Function | 4-3 |
| ALC Theory of Operation | 4-3 |
| ALC Measurement Time | 4-4 |
| ALC Voltage/Current Setting Range | 4-4 |
| Operation Procedure of the ALC Function | 4-4 |
| List Sweep Function | 4-5 |
| Structure of LIST SWEEP function | 4-5 |
| LIST SWEEP DISPLAY page | 4-5 |
| LIST SWEEP SETUP page | 4-5 |
| LIST SWEEP Measurement Procedure | 4-6 |
| Print Function | 4-9 |
| Print Mode | 4-9 |
| Printer Requirements | 4-10 |
| Printer Troubleshooting | 4-10 |
| | |
| 5. What's Next? | |

Index

Figures

| | |
|--|------|
| 1-1. Line Voltage Selector | 1-2 |
| 1-2. Bias Current System Configuration | 1-4 |
| 1-3. Q Measurement System Configuration | 1-5 |
| 1-4. Chaining the 42841A and the 42851A | 1-6 |
| 2-1. Front Panel Overview | 2-1 |
| 2-2. MENU Keys | 2-2 |
| 2-3. Entry Keys | 2-4 |
| 2-4. CURSOR Keys and Field Operation Example | 2-6 |
| 3-1. Connecting the 16047C | 3-2 |
| 3-2. Connecting a Shorting Bar | 3-3 |
| 3-3. Connecting DUT to the 16047C | 3-4 |
| 3-4. Measurement Results for a 220 pF Capacitor | 3-4 |
| 3-5. Connecting the 16034E | 3-6 |
| 3-6. 16034E Contacts in OPEN Condition | 3-7 |
| 3-7. Make the 16034E to SHORT Condition | 3-8 |
| 3-8. Connecting DUT to the 16034E | 3-9 |
| 3-9. Measurement Results of The Ferrite-Cored Inductor | 3-9 |
| 3-10. Connecting the 16047C | 3-11 |
| 3-11. Connecting A Shorting Bar | 3-12 |
| 3-12. Connecting DUT | 3-13 |
| 3-13. Voltage Biased (Option 001) Measurement Results | 3-13 |
| 3-14. Cable Correction Page | 3-15 |
| 3-15. 42102A 100Ω Resistor connection | 3-15 |
| 3-16. OPEN Termination Connection | 3-16 |
| 3-17. OPEN Termination (Alternative) | 3-16 |
| 3-18. SHORT Termination Connection | 3-17 |
| 3-19. SHORT Termination (Alternative) | 3-18 |
| 3-20. 100 Ω Resistor Connection | 3-18 |
| 3-21. 42842C Bias Current Test Fixture Connection | 3-21 |
| 3-22. High Current Biased Measurement Setup | 3-23 |
| 3-23. Open Condition of the 42842C | 3-24 |
| 3-24. Connecting the Furnished Shorting Bar | 3-25 |
| 3-25. Ferrite-Cored Inductor Measurement Results | 3-26 |
| 3-26. Precision Q Measurement Setup | 3-28 |
| 3-27. Connecting a Shorting Bar | 3-29 |
| 3-28. Connecting the SMD Test Fixture | 3-30 |
| 3-29. Connecting DUT to the SMD Test Fixture | 3-30 |
| 3-30. Inductor Precise Q Measurement Results | 3-31 |
| 4-1. Feedback Control Circuit | 4-3 |
| 4-2. Structure of LIST SWEEP Function | 4-5 |
| 4-3. List Sweep Modes | 4-7 |

Tables

| | |
|---|-----|
| 1-1. Line Voltage Selection | 1-2 |
| 1-2. Fuse Selection | 1-3 |
| 4-1. PRINT DISP and PRINT DATA Availability | 4-9 |

Before You Begin

Welcome to the 4285A Precision LCR Meter world. The 4285A (75 kHz – 30 MHz) sets a new standard in advanced component and materials measurement.

Use this guide to install and learn how to operate the 4285A quickly. Whatever you are a novice to LCR meter use or an experienced user, this guide will give you a working knowledge of the 4285A so that you can start using the 4285A immediately to evaluate your devices. This guide covers:

- Installation
- Front/Rear Panel Components
- Front Panel Operation
- Basic Measurement Examples
- Memory Function Structure
- Automatic Level Control Function Operation
- List Sweep Function Operation
- Printing Measurement Result
- Performing Error Correction Function

Initial Considerations

The 4285A has been carefully inspected both electrically and mechanically before being shipped from the factory. Verify this by carefully performing an incoming inspection to check the instrument for signs of physical damage, missing contents, and to check that it passes its electrical performance test. If any discrepancy is found, notify both the carrier and Agilent Technologies. For details of the performance test procedure, refer to the *4285A Maintenance Manual*, (Agilent part number 04285-90030).

Preparation for Use

Before turning the power on, the 4285A and its accessories must be installed and interconnected correctly.

Power Requirements

The 4285A requires the following power source:

Voltage : 90 to 132 Vac, 198 to 252 Vac

Frequency : 47 to 66 Hz

Power : 200 VA maximum

Line Voltage and Fuse Selection

Figure 1-1 illustrates the line voltage selection switch and fuseholder on the instrument's rear panel.

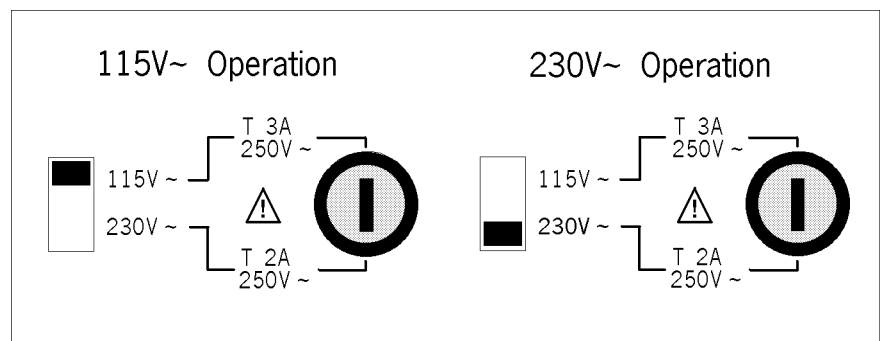

Figure 1-1. Line Voltage Selector

Caution



Before connecting the instrument to the power source, make sure that the correct fuse has been installed and the Line Voltage Selection Switch is correctly set.

Line Voltage Selection

Select the proper voltage selector according to the Table 1-1.

Table 1-1. Line Voltage Selection

| Voltage Selector | Line Voltage |
|------------------|---------------------|
| 115 V~ | 90-132 V, 47-66 Hz |
| 230 V~ | 198-252 V, 47-66 Hz |



Fuse Selection

Select proper fuse according to the Table 1-2. Current ratings for the fuse are printed under the fuseholder on the rear panel, and are listed, along with the fuse's Agilent part number, in Table 1-2.

Table 1-2. Fuse Selection

| Operating Voltage | Fuse Rating/Type | Fuse Part Number |
|--------------------------|--|-------------------------|
| 115 V~ | 3A 250Vac UL/CSA type Time Delay | 2110-0381 |
| 230 V~ | 2A 250Vac UL/CSA type Time Delay | 2110-0303 |

If you need this fuse, contact your nearest Agilent Technologies Sales and Service Office.

To remove the fuse, turn the fuse holder counterclockwise until the fuse pops out.

Caution



Use the proper fuse for the line voltage selected. Use only fuses with the required current rating and of the specified type as replacements. DO NOT use a mended fuse or short-circuit the fuse-holder in order to by-pass a blown fuse. Find out what caused the fuse to blow!

Setting Up the High Current DC Biased Measurement System

By combining with the 42841A and the 42842C, the 4285A can apply a maximum of 10A DC bias current to the device under test (DUT).

Equipment Required

To perform high current biased impedance measurement, the following equipment are required.

- 4285A Precision LCR Meter with Option 002
- 42841A Bias Current Source
- 42842C Bias Current Test Fixture
- 16048A Test Leads

Check the Option slots in the rear panel of the 4285A to confirm that Option 002 is installed. Option 002 has a 50 pin Amphenol connector, and is installed in the right most slot (looking from back), labeled ACCESSORY CONTROL INTERFACE.

Installing the Test Fixture

When you use the 42841A Bias Current Source with the 42842C Bias Current Test Fixture, connect the 42842C directly to the 42841A. The connection procedure is:

1. Put the guide rods of the 42842C into the guide holes in the front of the 42841A.
2. Connect the output terminal of the 42841A to the input terminal of the 42842C by pushing the 42842C toward the 42841A.
3. Rotate the retaining screws clockwise in front of the 42842C until it locks.

Interconnecting the Units

Interconnect the 4285A, the 42841A, and the 42842C using the proper cables as shown in Figure 1-2, use the following procedure.

1. Connect the UNKNOWN terminals of the 4285A and the TO UNKNOWN terminals of the 42842C with the 16048A Test Leads.
2. Connect the ACCESSORY CONTROL INTERFACE connector of the 4285A and the BIAS CONTROL INPUT A connector of the 42841A using the furnished accessory control interface cable.

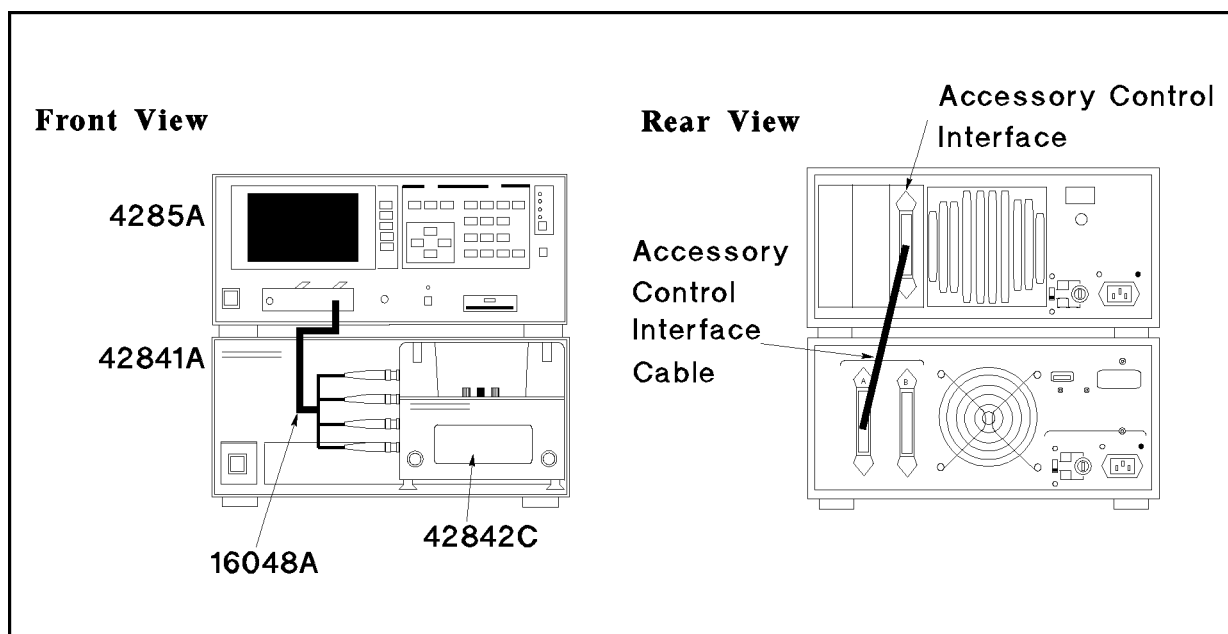

Figure 1-2. Bias Current System Configuration

Setting Up the Precision Q Measurement System

Combined with the 42851A, the 4285A performs precision Q measurement using the resonant measurement method.

Equipment Required

To perform precision Q measurement, the following equipment are required.

- 4285A Precision LCR Meter with Option 002
- 42851A Precision Q Adapter
- 10503A BNC Coaxial Cable (2 ea.)

Interconnecting the Units

Connect the cables between the 4285A and the 42851A as shown in Figure 1-3, use the following procedure.

1. Connect the UNKNOWN terminals of the 4285A and the TO UNKNOWN terminals of the 42851A using two 10503A BNC coaxial cables.

2. Connect the ACCESSORY CONTROL INTERFACE connector of the 4285A and the CONTROL INPUT connector of the 42851A using the furnished accessory control interface cable.

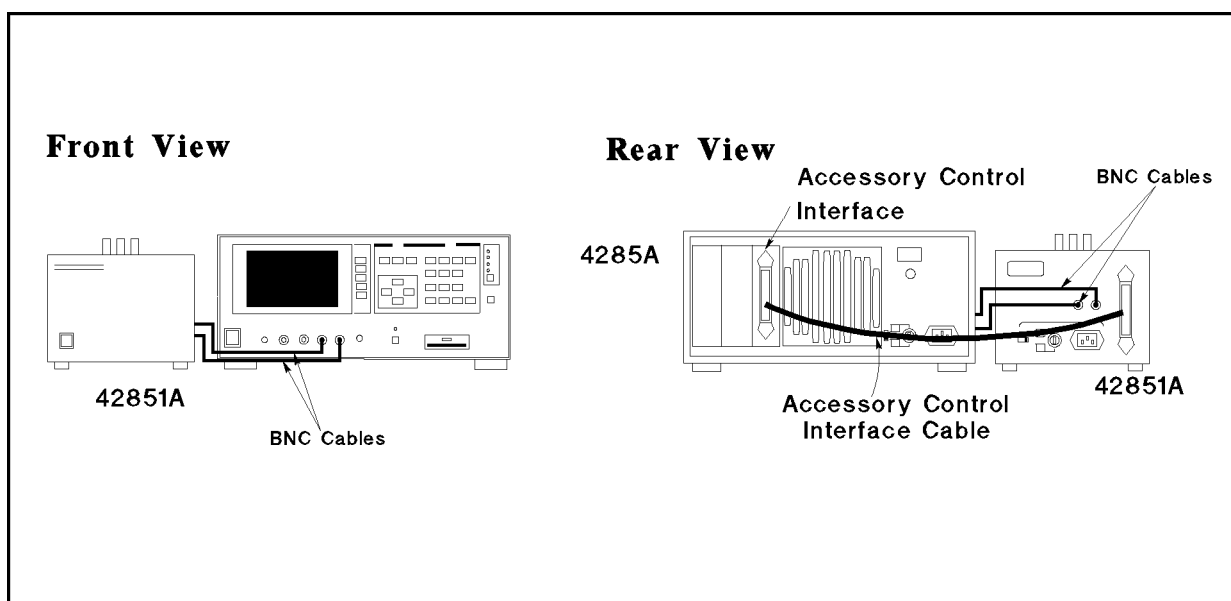

Figure 1-3. Q Measurement System Configuration

Connecting 4285A, 42841A, and 42851A

The 42841A and the 42851A use the same accessory control interface, and both of them can be connected to a 4285A. However, the 4285A can control either the 42841A or 42851A depending on the *CONFIG* field setting on the *SYSTEM CONFIG* page.

Equipment Required

The following equipment are required.

- 4285A Precision LCR Meter with Option 002
- 42841A Bias Current Source
- 42842C Bias Current Test Fixture
- 42851A Precision Q Adapter
- 16048A Test Leads
- 10503A BNC Coaxial Cable (2 ea.)

Interconnecting Cables

Connect the cables between the 4285A, the 42841A, and the 42851A as shown in Figure 1-4 using the following procedure.

1. Connect the ACCESSORY CONTROL INTERFACE connector of the 4285A and the BIAS CONTROL INPUT A connector of the 42841A using the furnished accessory control interface cable.
2. Connect the BIAS CONTROL INPUT B connector of the 42841A and the CONTROL INPUT connector of the 42851A using the furnished accessory control interface cable.

3. When you perform a high DC current bias measurement, connect the UNKNOWN terminals of the 4285A and the TO UNKNOWN terminals of the 42842C using the 16048A test leads.

When you perform a precision Q measurement, connect the UNKNOWN terminals of the 4285A and the TO UNKNOWN terminals of the 42851A using two 10503A BNC coaxial cables.

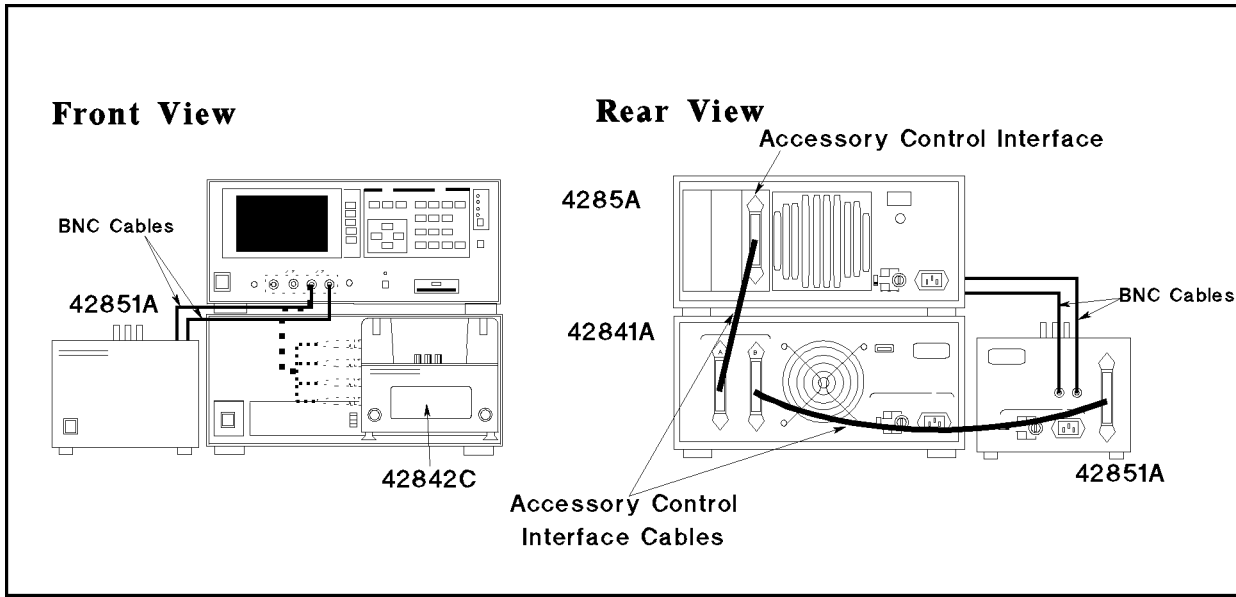

Figure 1-4. Chaining the 42841A and the 42851A

To learn how to use the 4285A Precision LCR Meter and its accessories, continue with the next chapter. The 4285A has already passed its self-test and is ready to make measurements.

If you want an electrical inspection (incoming inspection, for instance), go through the *4285A Maintenance Manual* (Agilent part number 04285-90030).

Getting Acquainted with the 4285A

Front Panel Description

Figure 2-1 shows the front panel of the 4285A. A description of the front panel is given in the following paragraphs.

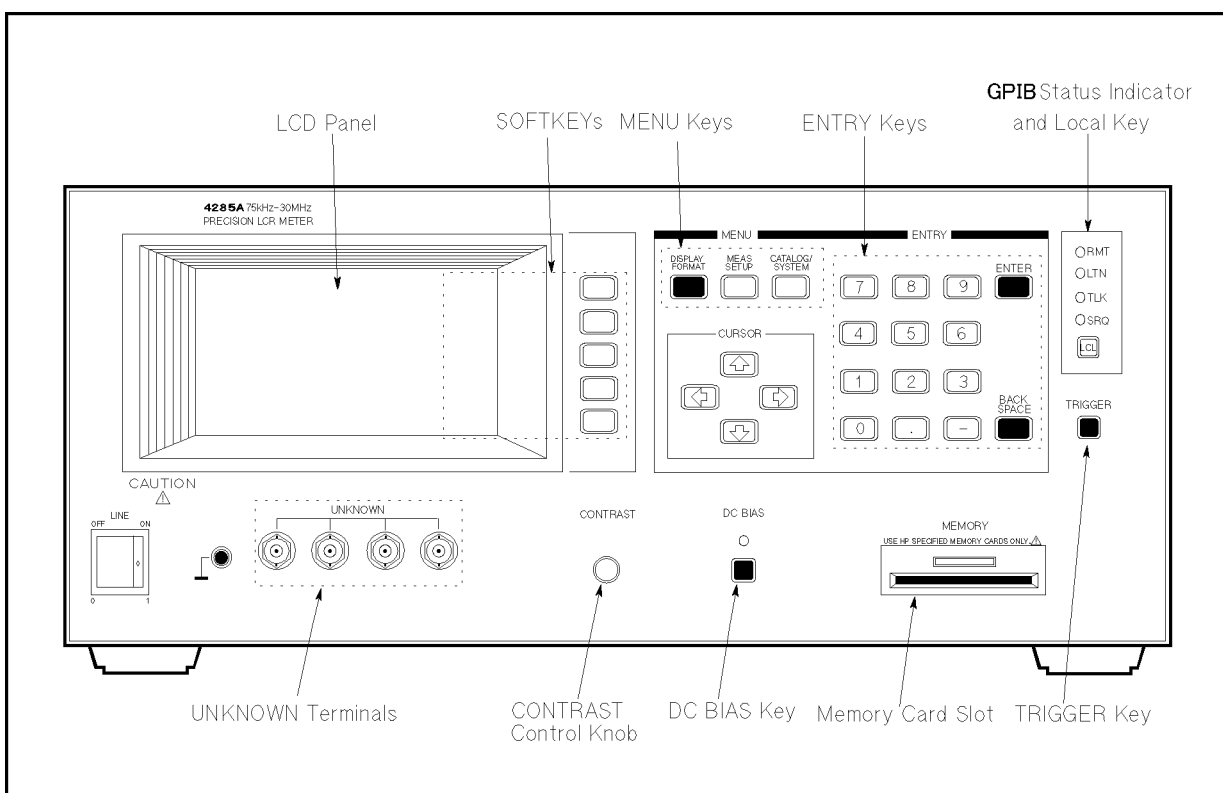

Figure 2-1. Front Panel Overview

LCD Panel and Softkey

To simplify the front panel by reducing the front panel keys for each of the many instrument functions, the 4285A employs LCD (Liquid Crystal Display)-displayed “menus” for operator input. These menus list the possible choices for a particular function, with each choice corresponding to one of the five softkeys located to the right of the LCD screen.

In this guide the two types of keys are differentiated in this way:

HARDKEY

Keys on the front panel

SOFTKEY

Keys located to the right of the LCD bezel

MENU keys and Display Pages

What is the Measurement Modes?



The 4285A changes the display format dynamically corresponding to the measurement mode and the MENU key pressed. These formats are called *DISPLAY pages*. (In this guide the page name is written in *ITALICS*.) The currently selected page name is displayed in the upper left corner of the LCD screen enclosed in the angle bracket.

The 4285A has following three measurement modes.

- Normal LCR measurement mode which uses the auto balancing bridge measurement method.
- Precision Q measurement when combined with the 42851A.
- High current DC biased measurement when combined with the 42841A and 42842C.

These measurement modes can be changed on the *CONFIG* field in *SYSTEM CONFIG* page under CATALOG/SYSTEM.

The 4285A has three MENU keys, and each MENU key has four display pages as follows.

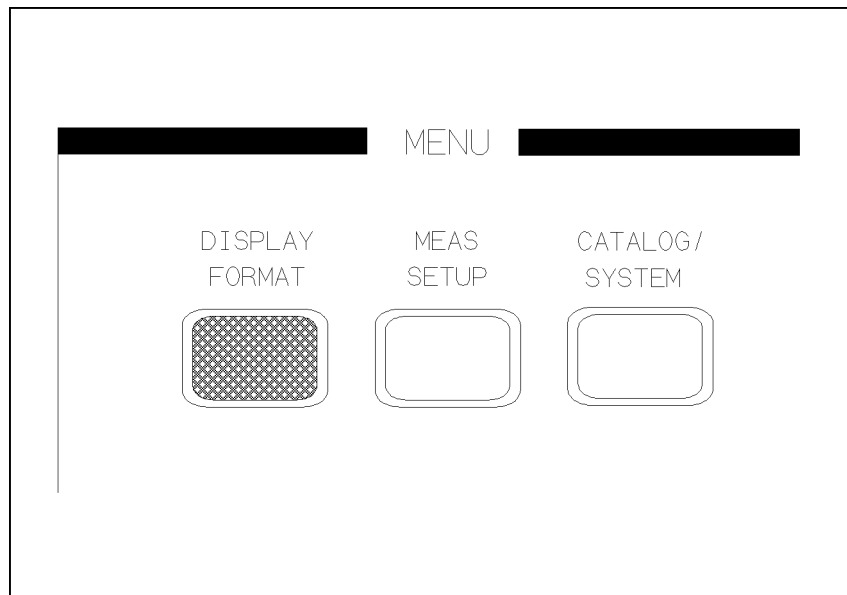

Figure 2-2. MENU Keys

■ DISPLAY FORMAT

The display pages under this menukey are used to choose the measurement display format, sorting, and sweep results. The 4285A performs measurement from only these pages. Some major selection fields can be set from these pages the same as from the fields on the *MEAS SETUP* page under MEAS SETUP. When the 4285A is turned on or, when you press DISPLAY FORMAT, *MEAS DISPLAY* page is automatically selected. Press a softkey to choose other pages.

- *MEAS DISPLAY* page
- *BIN No. DISPLAY* page
- *BIN COUNT DISPLAY* page

□ *LIST SWEEP DISPLAY* page

■ **MEAS SETUP**

The display pages under this menukey are used to set all measurement conditions (including the correction function), and to set the bin sorting limits. While these pages are displayed, the 4285A stops data acquisition. When you press **MEAS SETUP**, the *MEAS SETUP* page is automatically selected. Press a softkey to choose other pages.

- *MEAS SETUP* page
- *CORRECTION* page
- *LIMIT TABLE SETUP* page
- *LIST SWEEP SETUP* page

■ **CATALOG/SYSTEM**

The display pages under this menukey are used for internal memory/external memory card management, for system configuration, and for service functions. While these pages are displayed, the 4285A stops data acquisition. When you press **CATALOG/SYSTEM**, the *CATALOG* page is automatically selected. Press a softkey to choose other pages.

- *CATALOG* page
- *SYSTEM CONFIGURATION* page
- *CABLE CORRECTION* page
- *SELF TEST* page

Note



When the 42851A Precision Q Adapter is connected to the 4285A and activated, all display pages (format) under **DISPLAY FORMAT** and **MEAS SETUP** will be changed. For operation information, refer to “Precision Q Measurement” in Chapter 3.

Difference between Field and Monitor Area



A field is an area on the LCD screen to set an instrument function. A monitor area is an area on the LCD screen to indicate the status or value of each instrument function. Fields can be accessed by the CURSOR (described below), but a monitor area can't be accessed.

CURSOR and CURSOR Keys

A CURSOR is a movable indicator on the LCD panel that allows you to access desired fields on each display page. The CURSOR changes the field where it resides from the normal white background to a dark background (inverse video). The CURSOR keys are used to move the CURSOR to the field you wish to use. Corresponding to the field where the CURSOR resides, the 4285A changes the softkey labels.

ENTRY Keys

In some cases, it is necessary to supply numeric values for a chosen parameter, such as frequency or comparator limits. The ENTRY keys are used to input these values. The ENTRY keys are composed of the digits 0 to 9, a period (.), a minus sign (-), (ENTER), and (BACK SPACE). (ENTER) terminates numeric input data and enters the displayed value on the input line (second line from the bottom of the LCD screen). (BACK SPACE) deletes one last character of the input value. When you enter numeric values from the ENTRY keys, available units are displayed on the softkeys. These unit keys also terminate numeric input data and enters the displayed value on the input line in the specified unit.

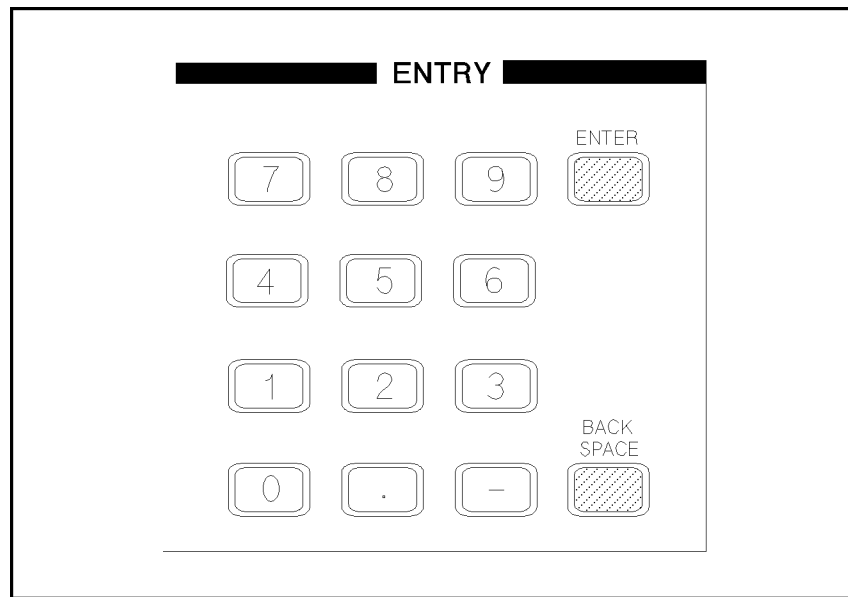

Figure 2-3. Entry Keys

GPIB Status Indicator and (LCL) Key

The General Purpose Interface Bus (GPIB) status indicators consist of the RMT (remote), TLK (talk), LTN (listen), and SRQ (service request) indicators. These indicators are used to show the 4285A's GPIB status when it is connected to a controller (computer) via GPIB. (LCL) (local) forces the 4285A to the local (front-panel) mode, if it was in remote mode and if the GPIB controller had not invoked a local lockout. (LCL) is the only front-panel key activated while the 4285A is in the remote mode.

(TRIGGER) Key

This key is used to manually trigger the 4285A when it is set to the manual trigger mode.

Memory Card Slot

This slot is used to connect a memory card which allows you to load or to store instrument settings except for correction information. Stored records can be checked on the *CATALOG* page.

The Memory card is ejected by pressing the UNLOCK button above the memory card slot.

Caution



Use Agilent-specified memory cards containing 4285A-specific data only. If other memory cards are used, the 4285A may be damaged. Non 4285A-specific data contained on a memory card is not guaranteed, and the data may be lost.

To insert a memory card into the MEMORY card slot, hold the memory card with the label facing up and with the contacts toward the slot opening. Insert the card into the slot until it *clicks* into place.

To remove a memory card from the 4285A, press the UNLOCK button and remove the card.

Do NOT remove a memory card while LOADING or STORING data. Doing so may damage the memory card and any data stored in the memory card may be lost.

Store memory cards in their furnished card cases when not in use. The card case protects memory cards from contamination and electrostatic discharge. Also, store memory cards under the following environmental conditions.

Storage Temperature Range: -30°C to $+70^{\circ}\text{C}$

Storage Humidity Range: 30% to 85% (@ $+50^{\circ}\text{C}$)

Do NOT shock or stress memory cards.

When storing or moving your 4285A, be sure the memory card slot is empty (no memory card inserted).

Do NOT touch the connector contact surface of a memory card and do NOT use liquid chemicals to clean the contacts.

DC-BIAS Key

This key is used to control the DC bias output. **DC BIAS** is a toggle type switch, and the DC BIAS on/off LED indicator is located above the **DC BIAS**. When **DC BIAS** is set to ON, the DC BIAS on/off LED indicator is ON. When **DC BIAS** is set to OFF, the DC BIAS on/off LED indicator is OFF. If the **DC BIAS** is set to OFF, even though the DC bias is set to ON according to the LCD display, the set DC bias isn't being output.

Contrast Control Knob

This knob controls the LCD's CONTRAST. When you can't read the LCD screen well, adjust this knob.

Front Panel Operation

Basic operation of the 4285A is described in the following paragraphs.

1. Display the desired display page using both the MENU keys and the softkeys.
2. Use the CURSOR keys to move the CURSOR to the field to be used. The CURSOR will be an inverse video marker, and the field is an area to which you can set the CURSOR. (Refer to Figure 2-4)

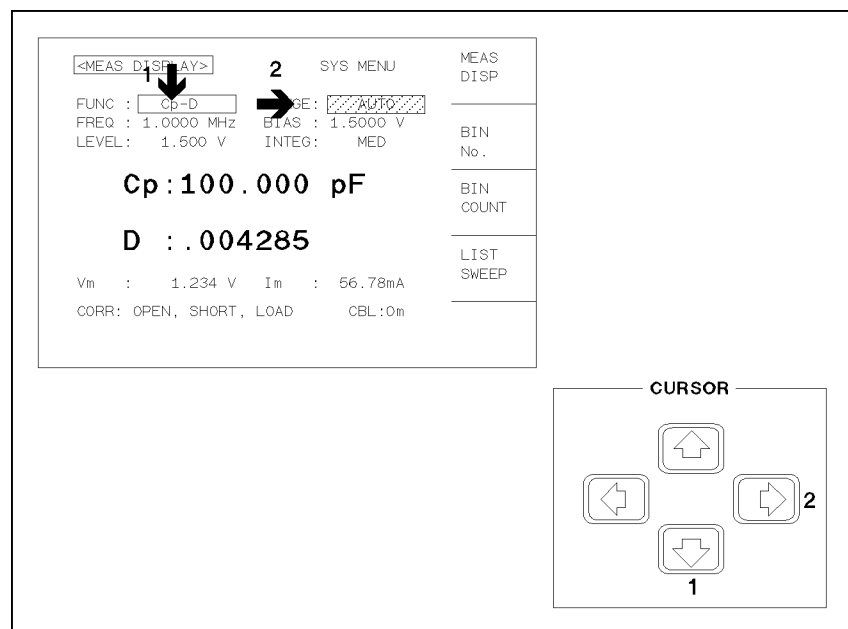

Figure 2-4. CURSOR Keys and Field Operation Example

3. Different softkeys will be displayed corresponding to the position of the CURSOR. Select and press a softkey. The numeric entry keys and **ENTER** are used to enter numeric data. When one of the numeric entry keys is pressed, the softkeys will change to the softkeys labeled by the unit names available. You can use these unit softkeys instead of **ENTER**. When **ENTER** is used, the numeric data is entered with the default unit depending on the CURSOR field selected, for example, test frequency's unit is Hz.

Basic Measurement Examples

Introduction

This chapter demonstrates several types of impedance measurements that can be made with the 4285A and its accessories. Each example includes the DUT's specifications, equipment required, measurement conditions, and operation procedures. The basic procedures to perform these measurements are the same as the "Front Panel Operation" in Chapter 2.

Capacitor Measurement

In this example a 220 pF ceramic capacitor will be measured under the following conditions.

DUT : 220 pF ceramic capacitor
 (Agilent Part Number 0160-4812)

Measurement Conditions

Function : C_p-D
 Frequency : 10 MHz
 Test Signal Level : 1 V

Equipment Required

- 16047C Test Fixture
- Shorting bar (Agilent Part Number 5000-4226) or equivalent

Operation Procedure

1. Turn the 4285A ON.
2. Set the 4285A to the normal LCR measurement mode which uses the auto balancing bridge measuring method.
 - a. Press **CATALOG/SYSTEM** and **SYSTEM CONFIG**. *SYSTEM CONFIG* page will now be displayed.
 - b. Move the CURSOR to *CONFIG* field. **I BIAS**, **Q ADAPTER**, and **OFF** will be displayed.
 - c. Press **OFF** to perform a normal LCR measurement.
3. Setup the 4285A's measurement conditions by modifying the fields on the *MEAS DISPLAY* page.

Set the *FREQ* field to 10 MHz. (The other functions, including the measurement function are left at the default settings.)

 - a. Move the CURSOR to the *FREQ* field. The current measurement frequency, 1.0000MHz is displayed in this field.
 - b. Press **1** and **0**. 10 will be displayed on the system message line, and the softkey labels will change to the available units (**kHz** and **MHz**). Press **MHz**. 10.0000MHz is now displayed in the *FREQ* field.

Note



The FREQUENCY can be changed using INCR \uparrow , INCR Δ Hz, DECR Δ Hz, and DECR \downarrow which are displayed when the CURSOR is moved to the *FREQ* field. INCR \uparrow and DECR \downarrow set a frequency from the following default 28 frequencies.

| | | | |
|--------|---------|---------|--------|
| 75 kHz | 100 kHz | 1 MHz | 10 MHz |
| 80 kHz | 120 kHz | 1.2 MHz | 12 MHz |
| | 150 kHz | 1.5 MHz | 15 MHz |
| | 200 kHz | 2 MHz | 20 MHz |
| | 250 kHz | 2.5 MHz | 25 MHz |
| | 300 kHz | 3 MHz | 30 MHz |
| | 400 kHz | 4 MHz | |
| | 500 kHz | 5 MHz | |
| | 600 kHz | 6 MHz | |
| | 800 kHz | 8 MHz | |

INCR Δ Hz and DECR Δ Hz increment and decrement the current test frequency with the specified step value respectively. The step value can be changed with Δ kHz and Δ MHz, which will be displayed when the numeric value is entered from the entry keys. The default step value is 100 Hz.

Note



The measurement conditions can also be set on the *MEAS SETUP* page displayed when **MEAS SETUP** is pressed. The setup operation on the *MEAS SETUP* page is the same as in the preceding steps from 2 to 3.

4. Connect the test fixture to the 4285A.

The 16047C Test Fixture is used for this measurement example.

Connect the 16047C to the 4285A's UNKNOWN terminals, as shown in Figure 3-1.

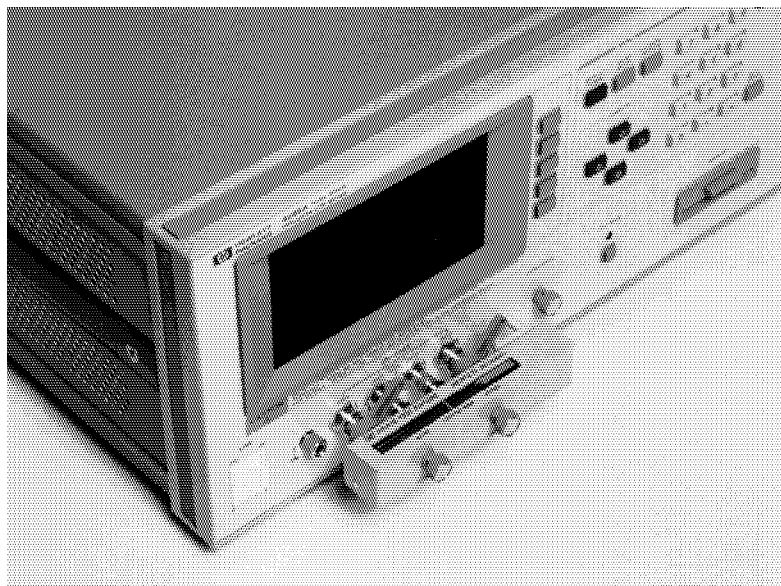

Figure 3-1. Connecting the 16047C

5. Perform error correction.

To compensate for the 16047C's residuals and strays, OPEN/SHORT correction is required.

- a. Leave the 16047C OPEN as shown in Figure 3-1.
- b. Press **MEAS SETUP** and **CORRECTION**. The *CORRECTION* page is displayed.
- c. Move the CURSOR to the *OPEN* field. **ON**, **OFF**, and **MEAS OPEN** are displayed.
- d. Press **MEAS OPEN** to perform the OPEN correction data measurement. The message *OPEN measurement in progress* will be displayed on the system message line. Wait approximately 50 seconds until the message *OPEN measurement completed.* is displayed on the system message line.
- e. Press **ON** to set the OPEN correction function to ON.
- f. Connect a shorting bar to the 16047C to set up the SHORT condition as shown in Figure 3-2.

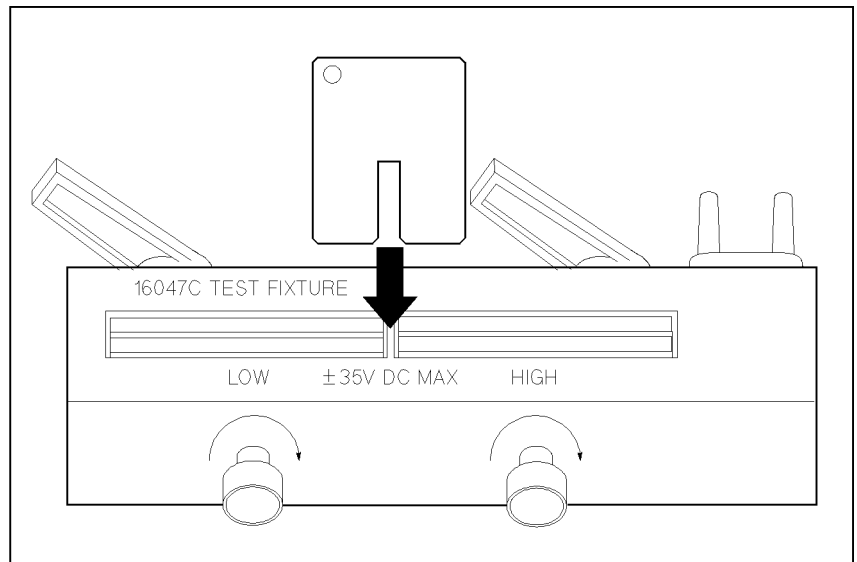

Figure 3-2. Connecting a Shorting Bar

- g. Move the CURSOR to the *SHORT* field. **ON**, **OFF**, and **MEAS SHORT** are displayed.
 - h. Press **MEAS SHORT** to perform the SHORT correction data measurement. The message *SHORT measurement in progress* will be displayed on the system message line. Wait approximately 50 seconds until the message *SHORT measurement completed.* is displayed on the system message line.
 - i. Press **ON** to set the SHORT correction function to ON.
6. Connect a DUT to the test fixture.

Insert the DUT into the 16047C's measurement contacts deeply as shown in Figure 3-3. Tighten the measurement terminal knob clockwise until the DUT is in firm contact with the 16047C's electrodes.

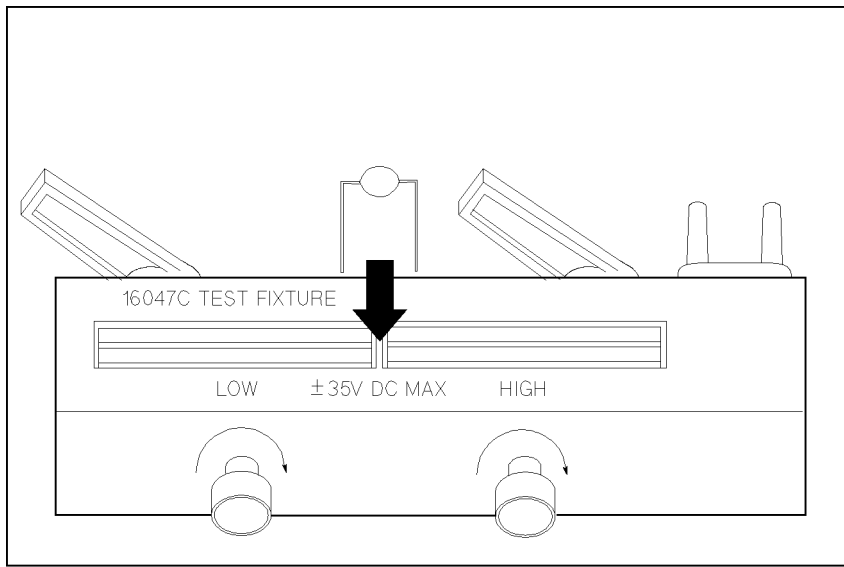

Figure 3-3. Connecting DUT to the 16047C

7. Perform the measurement.

Press **DISPLAY FORMAT**. The internal trigger starts and continuously repeats the measurements. The capacitor's measured C_p and D values are displayed in large characters as shown in Figure 3-4.

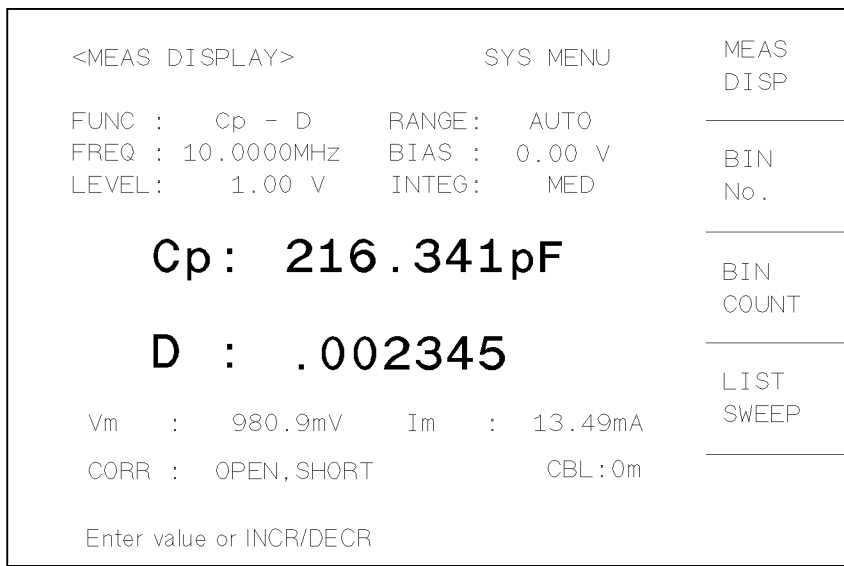

Figure 3-4. Measurement Results for a 220 pF Capacitor

Inductance Measurements

This section describes an example of measuring a chip type 470 nH ferrite-cored inductor. It will be measured under the following conditions.

DUT : Chip type 470 nH ferrite-cored inductor
(Agilent Part Number 9140-1235)

Measurement Conditions

Function : $L_s - R_s$
Frequency : 25.2 MHz
Test Signal Level : 10 mA (constant)

Equipment Required

- 16034E Test Fixture

Operation Procedure

1. Turn the 4285A ON.
2. Set the 4285A to the normal LCR measurement mode which uses the auto balancing bridge measuring method.
 - a. Press **CATALOG/SYSTEM** and **SYSTEM CONFIG**. *SYSTEM CONFIG* page will now be displayed
 - b. Move the CURSOR to the *CONFIG* field. **I BIAS**, **Q ADAPTER**, and **OFF** will be displayed.
 - c. Press **OFF** to perform a normal LCR measurement.
3. Setup the 4285A measurement conditions by filling in the fields on the *MEAS DISPLAY* page.

Set FUNCTION to L_s-R_s , FREQUENCY to 25.2 MHz, and LEVEL to 10 mA constant. (The other functions will be left at the default settings.)

 - a. Move the CURSOR to the *FUNC* field. The Current measurement function, C_p-D , is displayed in this field, and **Cp-D**, **Cp-Q**, **Cp-G**, **Cp-Rp**, and **more 1/6** are displayed.
 - b. Press **more X/6** until it is changed to **more 4/6** and **Ls-Rs** is displayed.
 - c. Press **Ls-Rs** to select the L_s-R_s measurement function.
 - d. Move the CURSOR to the *FREQ* field. The current measurement frequency, 1.0000MHz, will be displayed in this field.
 - e. Press **2**, **5**, **0**, and **2**. 25.2 will be displayed on the system message line, and the softkey labels will change to the available units (**kHz** and **MHz**). Press **MHz**. 25.2000MHz is displayed in the *FREQ* field.
 - f. Move the CURSOR to the *LEVEL* field. The current test signal level, 1.00V, will be displayed in this field.
 - g. Press **1** and **0**. 10 will be displayed on the system message line, and the softkey labels will change to the available units (**mV**, **V**, **µA**, and **mA**). Press **mA**. 10.0mA is displayed in the *LEVEL* field.

Note



The measurement conditions can also be set from the *MEAS SETUP* page displayed when **MEAS SETUP** is pressed. The setting operation on the *MEAS SETUP* page is same as in the preceding steps (a) to (g).

- h. Press **MEAS SETUP**. The *MEAS SETUP* page is displayed.
 - i. Move the CURSOR to the *ALC* field. The current status of the *ALC* function, **OFF**, is displayed in this field, and **ON** and **OFF** are displayed.
 - j. Press **ON** to set the test signal current level to be constant.
4. Connect the test fixture to the 4285A.

The 16034E chip Test Fixture (for chip components) is used for this measurement.

Connect the 16034E to the UNKNOWN terminals of the 4285A, as shown in Figure 3-5.

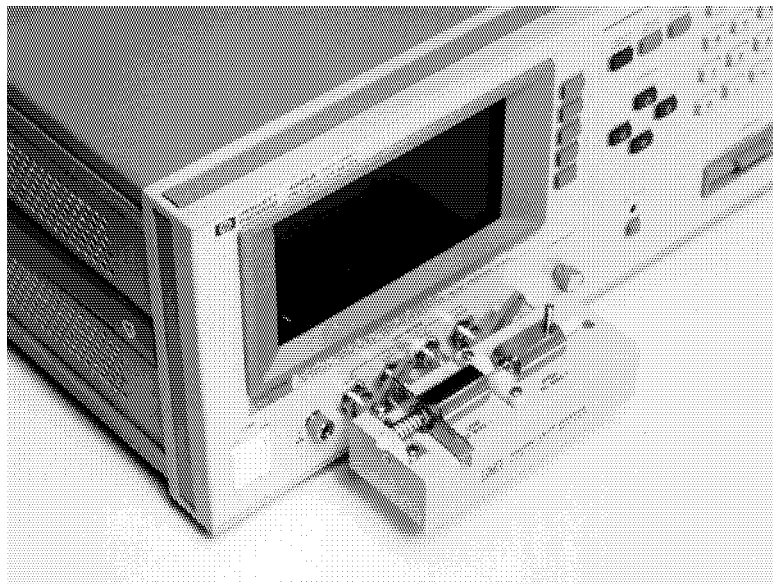

Figure 3-5. Connecting the 16034E

5. Perform OPEN/SHORT correction.

OPEN/SHORT correction is required to compensate the residual impedance and stray admittance of the 16034E.

- a. Leave the 16034E electrode contacts OPEN as shown in Figure 3-6. When measuring OPEN correction data, the distance between high and low contact electrodes should be same as when the DUT is connected.

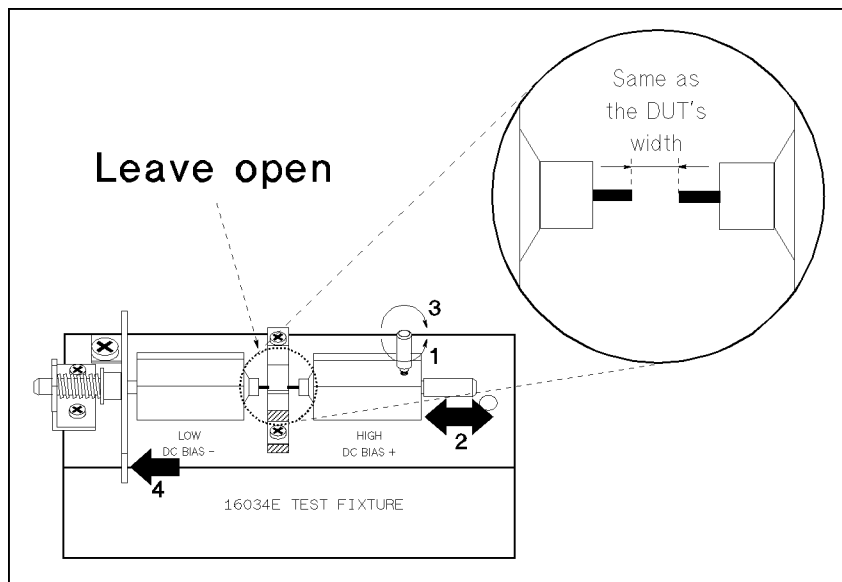

Figure 3-6. 16034E Contacts in OPEN Condition

- b. Press **MEAS SETUP** and **CORRECTION**. The *CORRECTION* page will be displayed.
- c. Move the CURSOR to the *OPEN* field. **ON**, **OFF**, and **MEAS OPEN** will be displayed.
- d. Press **MEAS OPEN** to perform the OPEN correction data measurement. Wait approximately 50 seconds until the message *OPEN measurement completed.* is displayed on the system message line.
- e. Press **ON** to set the OPEN correction function to ON.
- f. Connect the 16034E's two electrodes directly together to make a SHORT as shown in Figure 3-7.
 - i. Loosen the Knob.
 - ii. Push the end of the high electrode.
 - iii. Tighten the knob as shown in Figure 3-7.

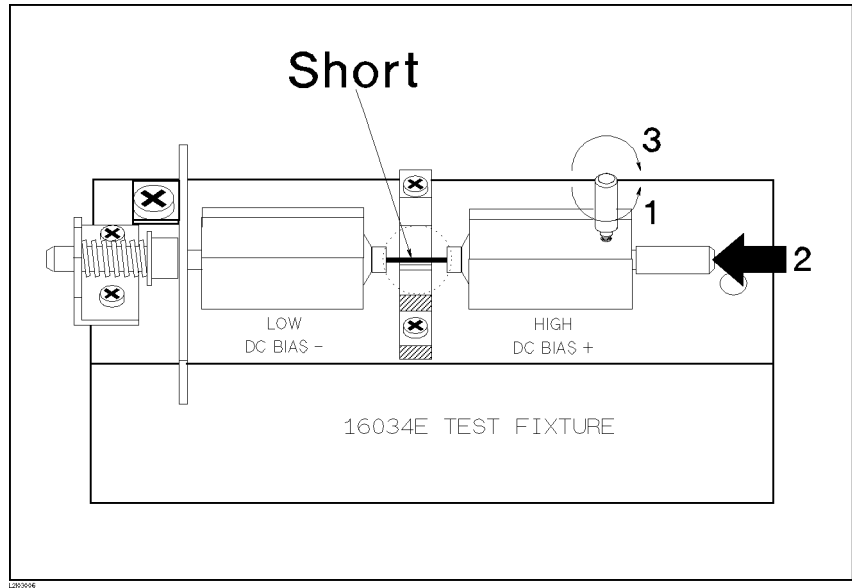

Figure 3-7. Make the 16034E to SHORT Condition

- g. Move the CURSOR to the *SHORT* field. **ON**, **OFF**, and **MEAS SHORT** will be displayed.
 - h. Press **MEAS SHORT** to perform the SHORT correction data measurement. Wait approximately 50 seconds until the message **SHORT measurement completed.** is displayed on the system message line.
 - i. Press **ON** to set the SHORT correction function to ON.
6. Connect the DUT to the test fixture.
- Place the DUT on the 16034E's measurement block, as shown in Figure 3-8.

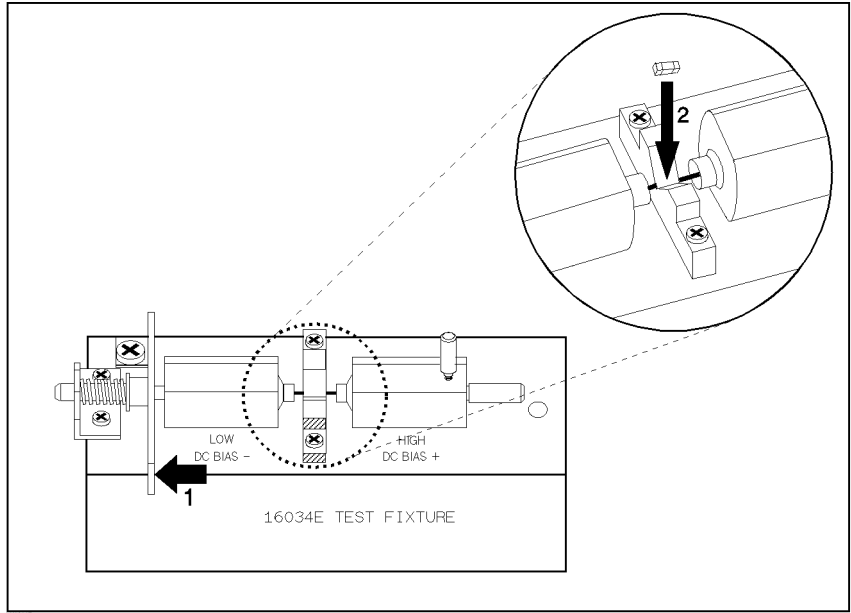

Figure 3-8. Connecting DUT to the 16034E

7. Perform the measurement.

Press **DISPLAY FORMAT**. The Internal trigger starts and continuously repeats the measurement. The measured L_s and R_s values of the ferrite-cored inductor are displayed in large characters as shown in Figure 3-9.

```

<MEAS DISPLAY>          SYS MENU
FUNC : Ls-Rs           RANGE:  AUTO
FREQ : 25.2000MHz     BIAS :  0.000 V
LEVEL:* 10.0mA       INTEG:  LONG

      L s :  4 5 5 . 6 8 7 n H

      R s :  1 . 6 6 4 1 9

Vm : 957.5mV          Im : 10.01mA
CORR:OPEN,SHORT      CBL:0m
  
```

Figure 3-9. Measurement Results of The Ferrite-Cored Inductor

DC Voltage Biased Measurement

When the 4285A is equipped with Option 001 DC Bias, $\pm 40\text{V}$ ($\leq 100\text{ mA}$) DC bias can be applied to the DUT.

In this example, a 470 pF capacitor will be measured under the following conditions.

DUT : 470 pF ceramic capacitor
 (Agilent Part Number 0160-4808)

Measurement Conditions

Function : $C_p - D$
Frequency : 5 MHz
Test Signal Level : 1 V (Constant)
DC Bias Level : 5 V

Equipment Required

- 4285A with Option 001
- 16047C Test Fixture
- Shorting bar (Agilent Part Number 5000-4226) or equivalent

Preparation Before Measurement

Checking the Option Installed

First of all, confirm that your 4285A is equipped with the Option 001. To do this, press **CATALOG/SYSTEM** and **SYSTEM CONFIG**, and check the *DC BIAS (#001)* monitor area. When **INSTALLED** is displayed in this area, your 4285A is equipped with Option 001.

Operation Procedure

1. Turn the 4285A ON.
2. Set the 4285A to the normal LCR measurement mode which uses the auto balancing bridge measuring method.
 - a. Press **CATALOG/SYSTEM** and **SYSTEM CONFIG**. *SYSTEM CONFIG* page will now be displayed
 - b. Move the CURSOR to the *CONFIG* field. **I BIAS**, **Q ADAPTER**, and **OFF** will be displayed.
 - c. Press **OFF** to perform the normal LCR measurement.
3. Setup the 4285A measurement conditions by modifying the fields on the *MEAS DISPLAY* page.

Set FREQUENCY to 5 MHz and LEVEL to a constant 1 V. (The other functions will be left at the default settings.)

 - a. Move the CURSOR to the *FREQ* field. The current measurement frequency, 1.0000MHz, will be displayed in this field.
 - b. Press **5**. 5 will be displayed on the system message line, and the softkey labels are changed to the available units (**kHz** and **MHz**). Press **MHz**. 5.0000MHz will be new displayed in the *FREQ* field.
 - c. Press **MEAS SETUP**. The *MEAS SETUP* page will be displayed.

- d. Move the CURSOR to the *ALC* field, and **ON** and **OFF** will be displayed.
 - e. Press **ON** to set the test signal voltage level to be constant.
4. Connect the test fixture to the 4285A.

The 16047C test fixture is used for this measurement.

Connect the 16047C to the UNKNOWN terminals of the 4285A, as shown in Figure 3-10.

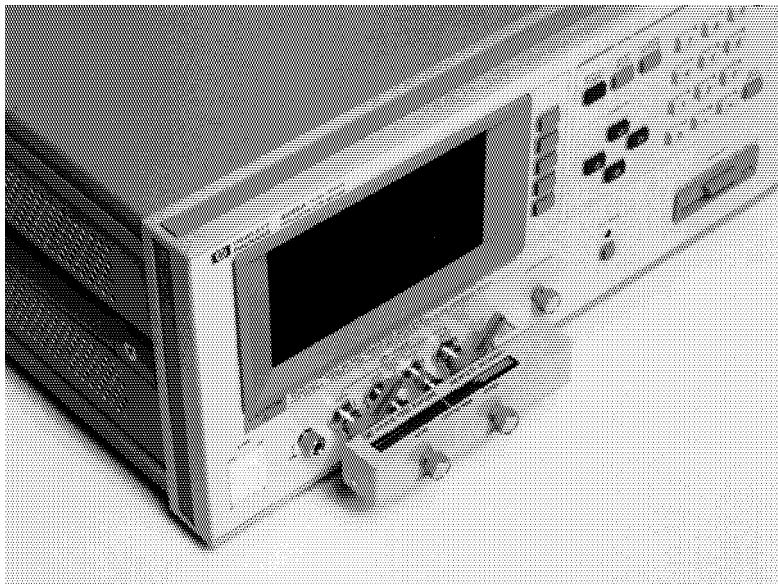

Figure 3-10. Connecting the 16047C

5. Perform OPEN/SHORT correction.

OPEN/SHORT correction is required to compensate the 16047C's residuals impedance and strays admittance.

- a. Leave the 16047C in an OPEN condition as shown in Figure 3-10.
- b. Press **MEAS SETUP** and **CORRECTION**. The *CORRECTION* page will now be displayed.
- c. Move the CURSOR to the *OPEN* field. **ON**, **OFF**, and **MEAS OPEN** will be displayed.
- d. Press **MEAS OPEN** to perform the OPEN correction data measurement. Wait until the message *OPEN measurement completed.* will be displayed on the system message line. It will take approximately 45 seconds.
- e. Press **ON** to set the OPEN correction function to ON.
- f. Connect a shorting bar to the 16047C to set up the SHORT condition as shown in Figure 3-11.

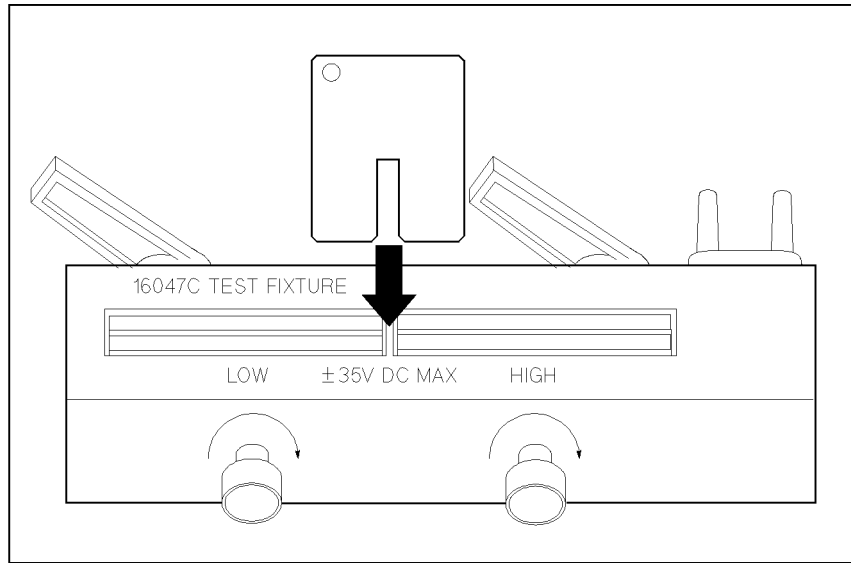

Figure 3-11. Connecting A Shorting Bar

- g. Move the CURSOR to the *SHORT* field. **ON**, **OFF**, and **MEAS SHORT** will be displayed.
 - h. Press **MEAS SHORT** to perform the SHORT correction data measurement. Wait until the message **SHORT measurement completed.** will be displayed on the system message line.
 - i. Press **ON** to set the SHORT correction function to ON.
6. Connect a DUT to the test fixture.
- Insert the DUT into the 16047C's measurement contacts deeply as shown in Figure 3-12.

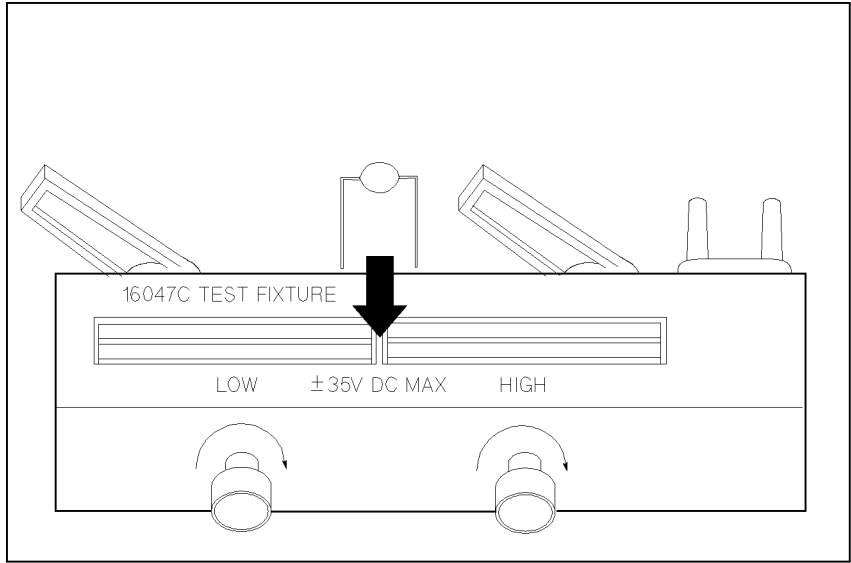
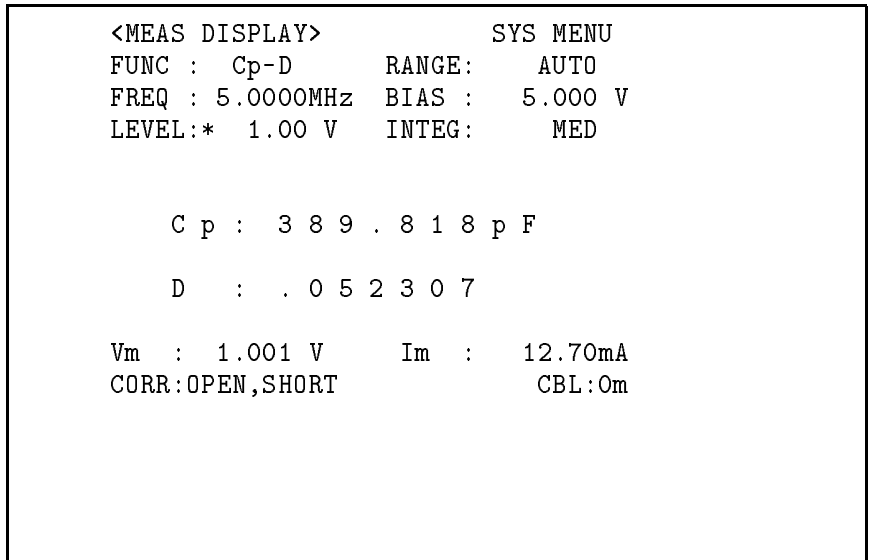

Figure 3-12. Connecting DUT

7. Perform the measurement.

Press **MEAS FORMAT**.

Internal trigger causes measurements to be performed continuously, and the capacitors measured C_p and D values are displayed as large characters as shown in Figure 3-13.



**Figure 3-13.
Voltage Biased (Option 001) Measurement Results**

Measurements Using 1m/2m Test Leads

When you need to extend the measurement cable from the 4285A UNKNOWN terminals, use the 16048A (1 m) or 16048D(2 m) Test Leads.

Note



It is not recommended to use the extension cable other than the 16048A and 16048D. Using other types or different length of cables may increase the measurement error.

The measurement error due to an individual test leads is proportional to the square of the test frequency. Accordingly, even small test leads differences can't be ignored at high frequencies, such as 30 MHz.

If you never performed the CABLE CORRECTION (the first time you extended the test leads) or in case of changing the test leads, perform the cable correction described below to adopt the 4285A to the individual 16048A/D test leads. Once this cable correction is performed, the measured cable correction data is stored in non-volatile memory and is not lost when the 4285A is turned OFF.

Equipment Required

- 42100A or the following equivalents
 - 100 Ω Resister Box (Furnished to the 4285A)
(Agilent Part Number 04285-61001)
 - BNC female-female Adapter (Furnished to the 4285A)
(Agilent Part Number 1250-0080) 4 ea.
 - BNC Tee male-female-female Adapter
(Agilent Part Number 1250-0781) 2 ea.

Operation Procedure

1. Press **CATALOG/SYSTEM** and **CABLE CORREC**. The *CABLE CORRECTION* page will be displayed.
2. Move the CURSOR to the *CABLE CORRECTION MENU* field.
3. Press **1** or **2** and **ENTER** to select either 1 m or 2 m *CABLE CORRECTION* menu. The following instruction screen and softkeys are displayed.

| | | |
|---|----------|------------|
| <CABLE CORRECTION> | 1m cable | REF. 0m |
| 1 Connect 100 Ω resistor to UNKNOWN terminals | | OPEN |
| 2 Press REF 0m key | | |
| 3 Disconnect 100 Ω and connect 1m test cable | | SHORT |
| 4 Connect OPEN to test cable | | |
| 5 Press OPEN key | | |
| 6 Connect SHORT in place of OPEN | | |
| 7 Press SHORT key | | LOAD |
| 8 Connect 100 Ω in place of SHORT | | |
| 9 Press LOAD key | | |
| 10 Press SAVE key | | SAVE |
| — | | |
| Use softkeys to select | | |

Figure 3-14. Cable Correction Page

4. Connect the 42102A 100Ω Resistor of the 42100A to the 4285A UNKNOWN terminals as shown in Figure 3-15. If you don't have an 42100A, the furnished 100Ω Resistor Box (Agilent Part Number 04285-61001) can be used as a substitute.

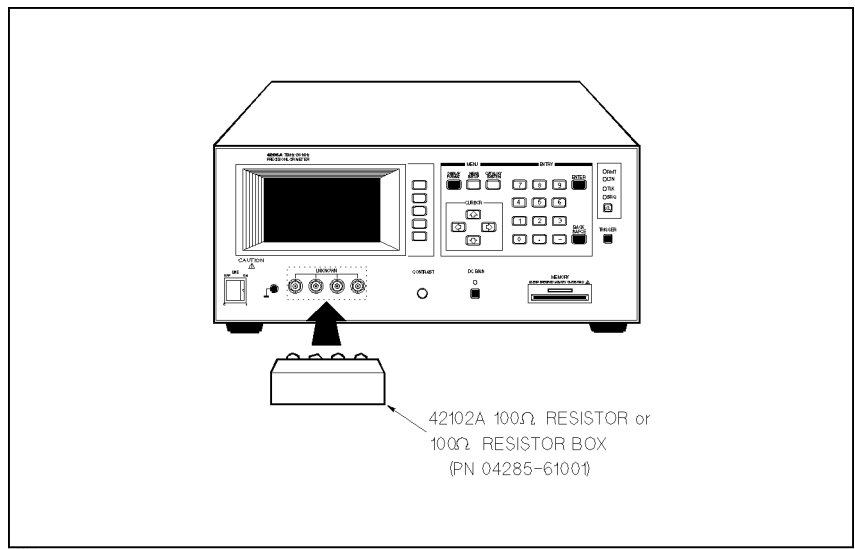

Figure 3-15. 42102A 100Ω Resistor connection

5. Press **REF. 0m**. REF measurement. will be displayed on the system message line. Wait until the 4285A beeps and displays the REF measurement complete. An * will be displayed on the left side of REF. 0m.
6. Connect 16048A/D Test Leads to the UNKNOWN terminals of the 4285A.

7. Connect the 42090A OPEN Termination of the 42100A and the 16048A/D Test Leads with the furnished BNC female-female adapters (Agilent Part Number 1250-0080) as shown in Figure 3-16.

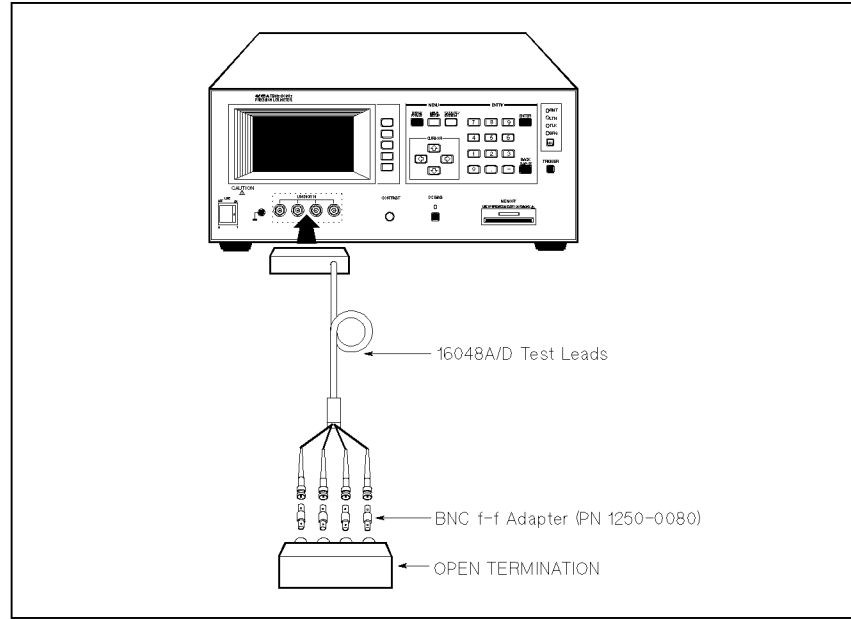

Figure 3-16. OPEN Termination Connection

If you don't have the 42090A OPEN Termination, configure as shown in Figure 3-17 using the furnished BNC f-f adapters.

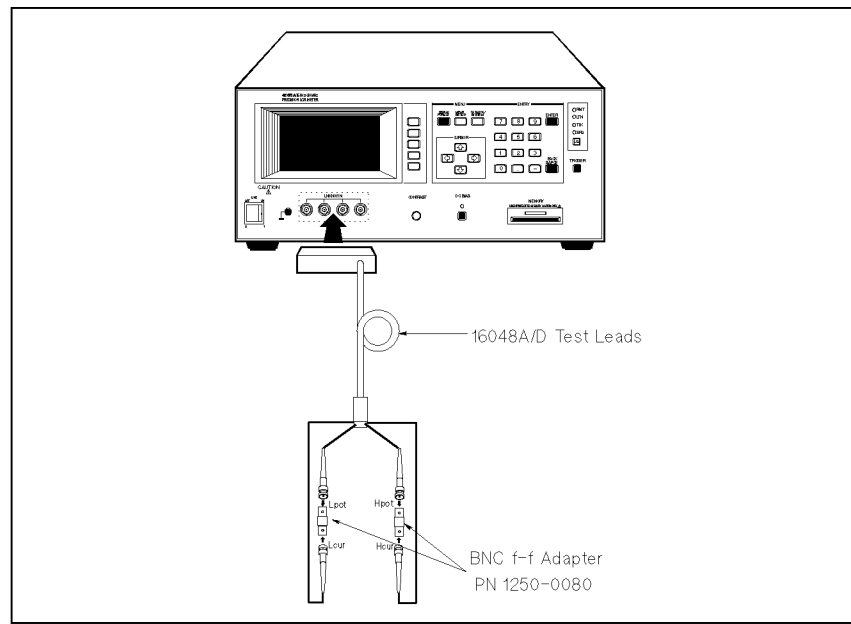

Figure 3-17. OPEN Termination (Alternative)

8. Press **OPEN**. OPEN measurement in progress will be displayed on the system message line. Wait until the 4285A beeps and displays the OPEN measurement completed. An * will be displayed on the left side of **OPEN**.
9. Connect the 42091A SHORT Termination of the 42100A and the 16048A/D test leads with the furnished BNC f-f adapters as shown in Figure 3-18.

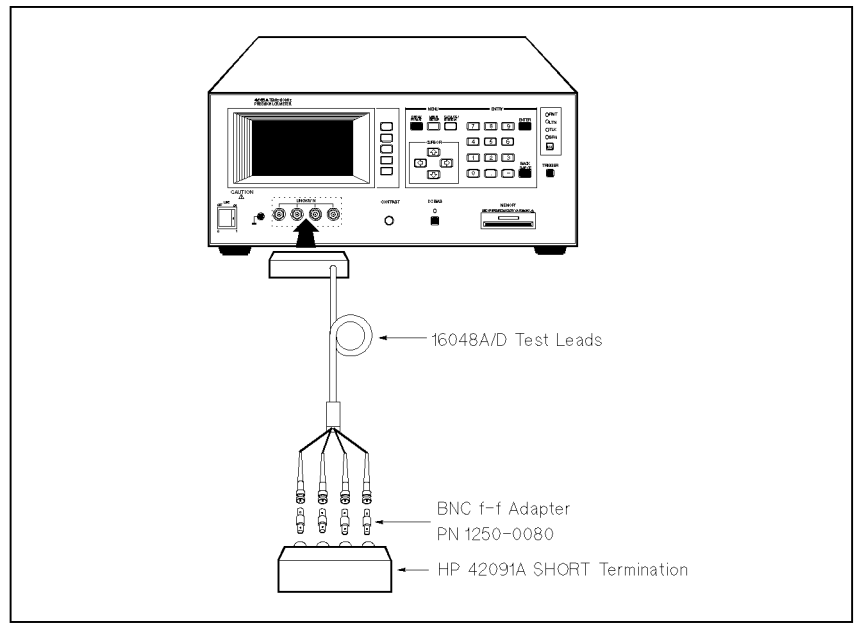

Figure 3-18. SHORT Termination Connection

If you don't have the 42091A SHORT Termination, configure as shown in Figure 3-19 with a BNC T m-f-f adapters and the furnished BNC f-f adapters.

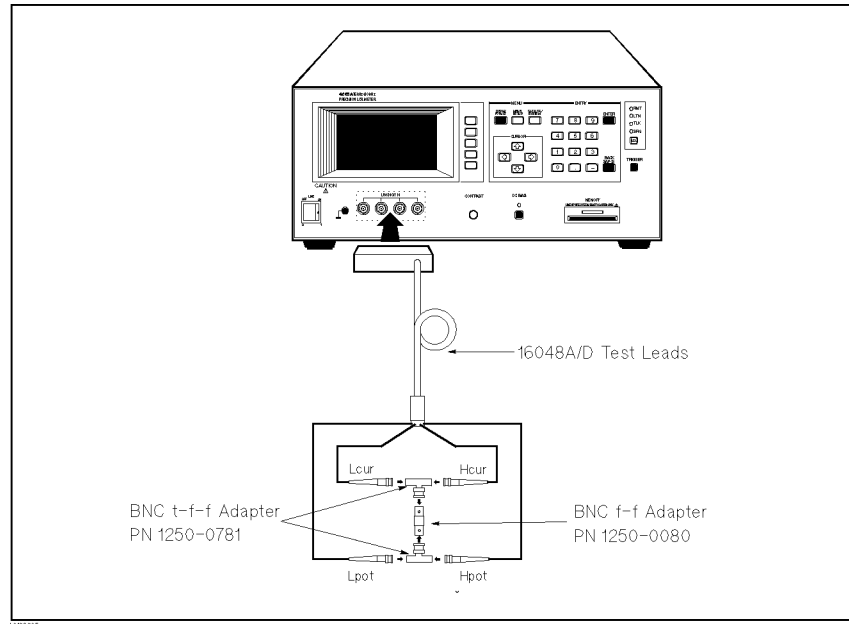

Figure 3-19. SHORT Termination (Alternative)

10. Press **SHORT**. **SHORT** measurement in progress will be displayed on the system message line. Wait until the 4285A beeps and displays the **SHORT** measurement completed. An * will be displayed on the left side of **SHORT**.
11. Connect the 42102A 100 Ω Resistor (or the furnished 100 Ω Resistor Box) and the 16048A/D test leads with the furnished BNC f-f adapters as shown in Figure 3-20.

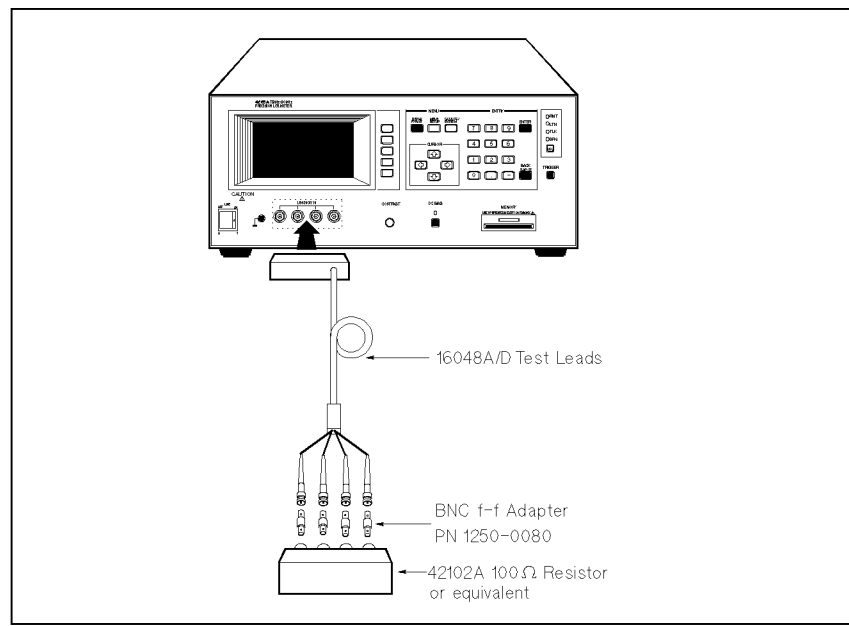

Figure 3-20. 100 Ω Resistor Connection

12. Press **LOAD**. LOAD measurement in progress will be displayed on the system message line. Wait until the 4285A beeps and displays the LOAD measurement completed. An * will be displayed on the left side of **LOAD**.
13. Press **SAVE**. Saving cable correction data ... will be displayed in the system message line. Wait until the 4285A beeps and displays the *CABLE CORRECTION* page.

Note



When different 16048A/D test leads are to be used, the cable correction measurement procedure must be redone.

DC Current Biased Measurement

When the 4285A is combined with the 42841A Bias Current Source and the 42842C Bias Current Test Fixture, 10A ($\leq 35V$) DC bias can be applied to the DUT.

In this example, a 330 nH inductor will be measured under the following conditions.

DUT : 330 nH inductor
 (Agilent Part Number 9100-2486)

Measurement Conditions

Function : $L_s - R_s$
Frequency : 25.2 MHz
Test Signal Level : 1 V
DC Bias Level : 1 A

Equipment Required

- 4285A with Option 002
- 42841A Bias Current Source
- 42842C Bias Current Test Fixture
- 16048A Test Leads

Preparation Before Measurement

First of all, performed the cable correction, if you have already performed the cable correction procedure described in “Measurements Using 1m/2m Test Leads”, skip to “Checking the Option Installed”.

Checking the Option Installed

First of all, confirm that your 4285A is equipped with Option 002. To do this, press **CATALOG/SYSTEM** and **SYSTEM CONFIG**, and check the *ACCESSORY I/F (#002)* monitor area. When **INSTALLED** is displayed in this area, your 4285A is equipped with Option 002.

Configuring the High Current Biased Measurement System

When you use the 42841A Bias Current Source with the 42842C Bias Current Test Fixture, connect the 42842C directly to the 42841A as shown in Figure 3-21.

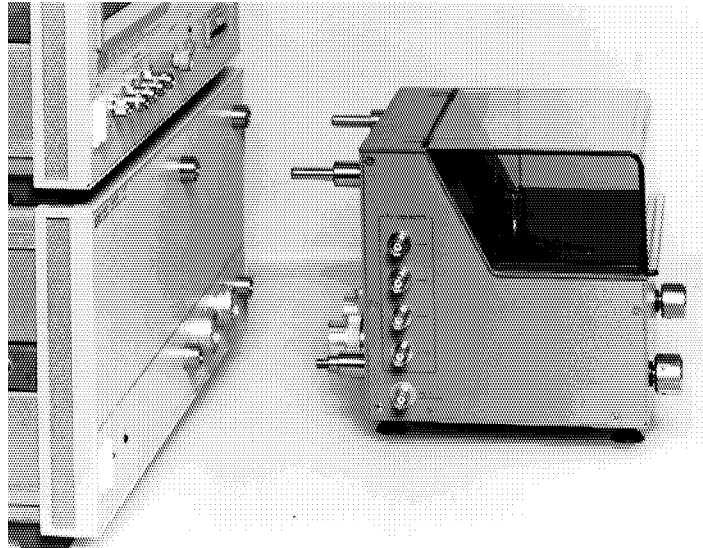

Figure 3-21. 42842C Bias Current Test Fixture Connection

The connection procedure is as follows.

1. Put the guide rods of the 42842C into the guide holes on the front of the 42841A.
2. Connect the input terminal of the 42842C to the output terminal of the 42841A pressing the 42842C toward the 42841A.
3. Rotate retaining screws clockwise in front of the 42842C until it rocks.

Warning



The 42842C mounted on the 42841A must be placed on a desk or bench. DO NOT stack the 42841A with the 42842C and the 4285A, DO NOT put any thing on the 42842C, and DO NOT lean on it, as shown below. Doing this may cause the instrument to tumble over.

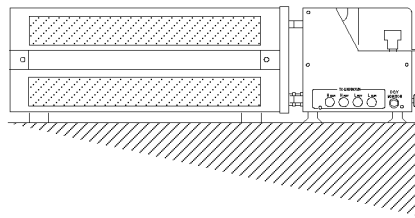
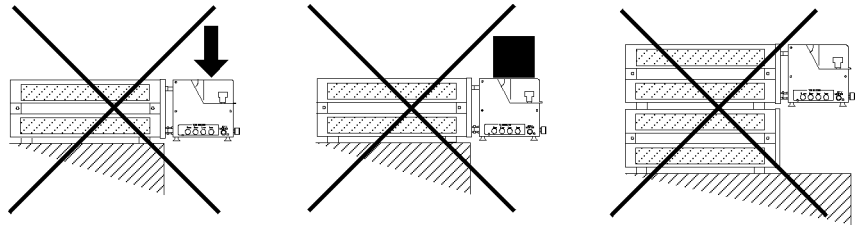

Recommended Physical Setup

The 4285A, the 42841A, and the 42842C must be connected with a bias current interface cable and 16048A test leads as shown in Figure 3-22 using the following procedure.

1. Connect the UNKNOWN terminals of the 4285A and the *TO UNKNOWN* terminals of the 42842C using the 16048A test leads.
2. Connect the *ACCESSORY CONTROL INTERFACE* connector of the 4285A and the *BIAS CONTROL INPUT A* connector of the 42841A with the furnished interface cable.

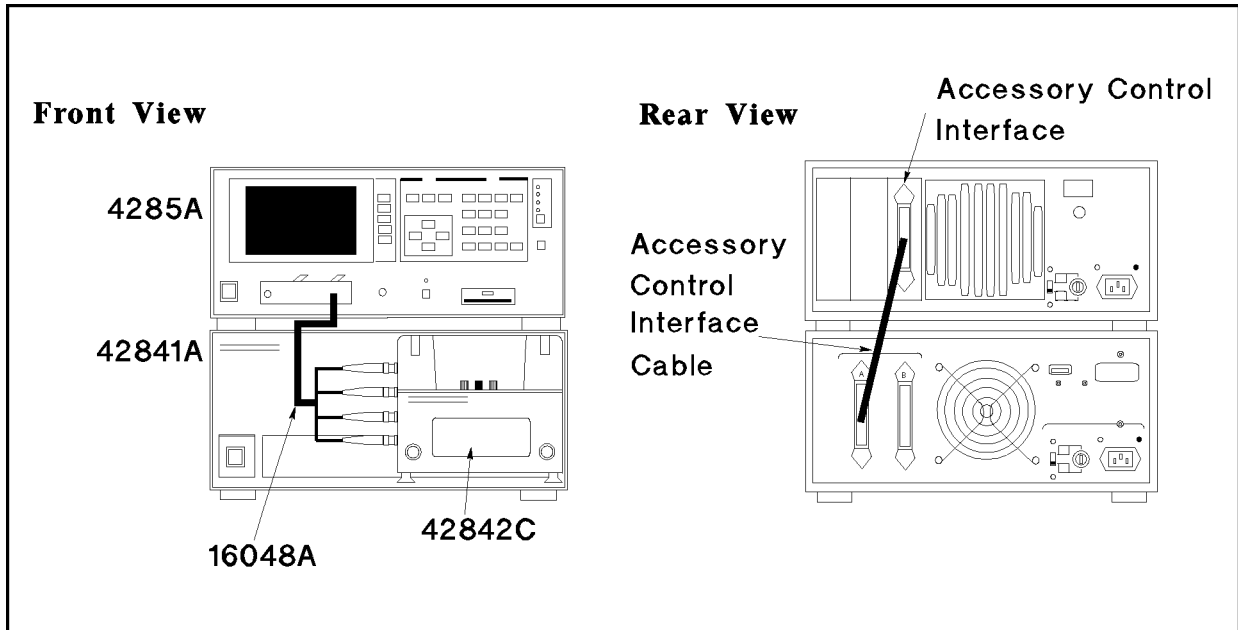

Figure 3-22. High Current Biased Measurement Setup

Operation Procedure

1. Turn the 4285A and 42841A ON.
2. Set the 4285A to the I BIAS mode to control the 42841A via the Option 002 Accessory Control Interface.
 - a. Press **CATALOG/SYSTEM** and **SYSTEM CONFIG**. *SYSTEM CONFIG* page is displayed
 - b. Move the CURSOR to the *CONFIG* field. **I BIAS**, **Q ADAPTER**, and **OFF** are displayed.
 - c. Press **I BIAS** to perform a DC current biased LCR measurement with the 42841A and the 42842C.
3. Setup the 4285A measurement conditions by modifying the fields on the *MEAS DISPLAY* page.

Set the frequency to 25.2 MHz and the DC bias level to 1A. (Other settings are left at the default settings.)

- a. Move the CURSOR to the *FREQ* field. The current measurement frequency, 1.0000MHz, will be displayed in this field.
- b. Press **2**, **5**, **.**, and **2**. 25.2 is displayed on the system message line, and the softkey labels change to the available units **kHz** and **MHz**. Press **MHz**. 25.2000MHz will be displayed on the *FREQ* field.
- c. Move the CURSOR to the *BIAS* field. The current DC bias level, 0.00 mA will be displayed in this field.
- d. Press **1**. 1 will be displayed on the system message line, and the softkey labels change to the available units **mV**, **V**, **μA**, **mA**, and **A**. Press **A**. 1 A will be displayed on the *BIAS* field.

4. Perform OPEN/SHORT correction.

OPEN/SHORT correction is required to compensate for the 42842C's residual impedance and stray admittance.

- a. Press **MEAS SETUP** and **CORRECTION**. The *CORRECTION* page will be displayed.
- b. Leave the 42842C OPEN as shown in Figure 3-23

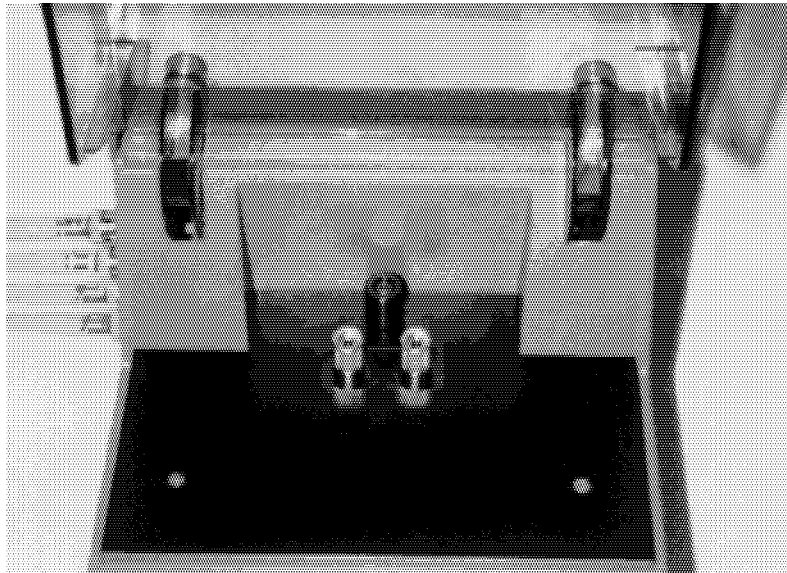

Figure 3-23. Open Condition of the 42842C

- c. Move the CURSOR to the *OPEN* field. **ON**, **OFF**, and **MEAS OPEN** are displayed.
- d. Press **MEAS OPEN** to perform the OPEN correction data measurement. Wait approximately 50 seconds until the message **OPEN measurement completed** will be displayed on the system message line.
- e. Press **ON** to set the OPEN correction function to ON.
- f. Connect furnished shorting bar to the 42842C to set up the SHORT condition as shown in Figure 3-24.

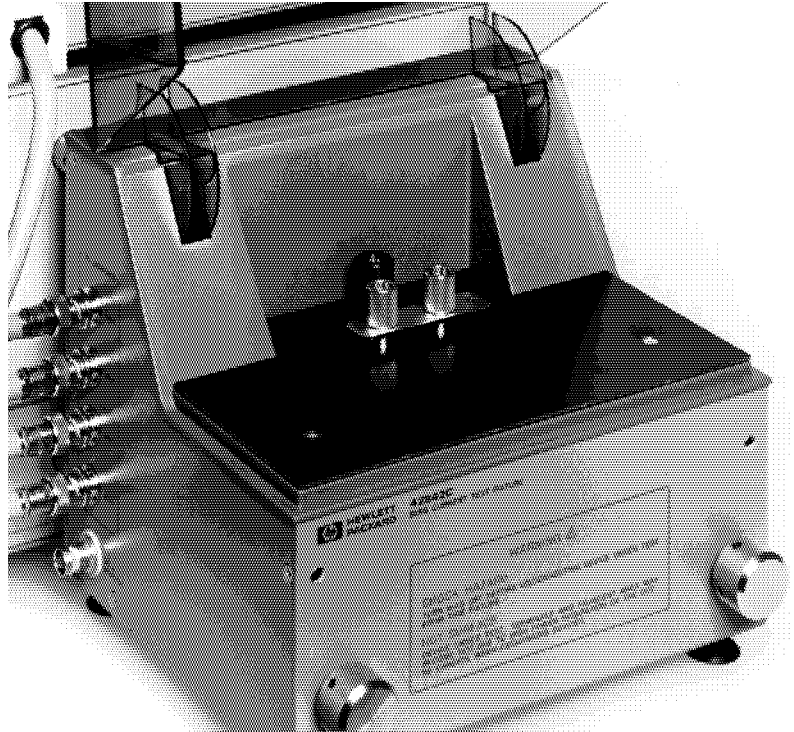

Figure 3-24. Connecting the Furnished Shorting Bar

- g. Move the CURSOR to the *SHORT* field. **ON**, **OFF**, and **MEAS SHORT** are displayed.
 - h. Press **MEAS SHORT** to perform the SHORT correction data measurement. Wait approximately 50 seconds until the message **SHORT measurement completed** will be displayed on the system message line.
 - i. Press **ON** to set the SHORT correction function to ON.
5. Connect the DUT to the test fixture.
Connect the DUT to the 42842C measurement terminals and close the test fixture protective cover.
 6. Enable the DC bias output.
Press **(DC BIAS)** on the 4285A front panel to turn the DC bias ON. The DC bias on/off LED indicators of the 4285A and the 42841A will come ON simultaneously.
 7. Perform the measurement.
Press **(DISP FORMAT)**. Internal trigger starts and continuously repeats measurement. The measured L_s and R_s values of the inductor are displayed in large characters as shown in Figure 3-25.

```
<MEAS DISPLAY>          SYS MENU
FUNC : Ls-Rs      RANGE:  AUTO
FREQ :25.2000MHz  BIAS :  1.000 A
LEVEL:* 1.00 V   INTEG:   MED

      L s :  2 9 6 . 4 6 6 n H

      R s :  0 . 8 2 9 0 1

Vm   :  809.8mV      Im   :  15.73mA
CORR: OPEN,SHORT    CBL: 1m
```

Figure 3-25. Ferrite-Cored Inductor Measurement Results

8. Disable DC bias output.

When the measurement is finished, turn the DC bias OFF by pressing **(DC BIAS)** to prevent the DUT from overheating. The DC bias on/off LED indicators of the 4285A and the 42841A will go off simultaneously.

Precision Q Measurement

This section describes an example of measuring a 10 μH ferrite-cored inductor. It will be measured under the following conditions.

DUT : 10 μH ferrite-cored chip inductor
(Agilent Part Number 9140-1238)

Measurement Conditions

Connection : DIRECT
Function : Q - L
Frequency : 2.52 MHz
Oscillator Level : 150 mV

Equipment Required

- 4285A with Option 002
- 42851A with Option 001
- 10503A coaxial cable (2 ea.)
or equivalents (50 Ω coaxial cable, BNC male connectors (2 ea.), ≤ 2 m)

For example, the 16048A/D test leads can also be used.

Preparation Before Measurement

Checking the Option Installed

First of all, confirm that your 4285A is equipped with Option 002. To do this, press **CATALOG/SYSTEM** and **SYSTEM CONFIG**, and check the *ACCESSORY I/F (#002)* monitor area. When the **INSTALLED** is displayed in this area, your 4285A is equipped with the Option 002.

Configure the Precision Q measurement System

The 4285A and the 42851A Precision Q Adapter must be connected with a interface cable and 16048A test leads as shown in Figure 3-26 using the following procedure.

1. Connect the H_{cur} and H_{pot} of the 4285A UNKNOWN terminals and the TO UNKNOWN terminals of the 42851A using the 10503A BNC coaxial cables.
2. Connect the ACCESSORY CONTROL INTERFACE connector of the 4285A and the CONTROL INPUT connector of the 42851A with the interface cable furnished to the 42851A.

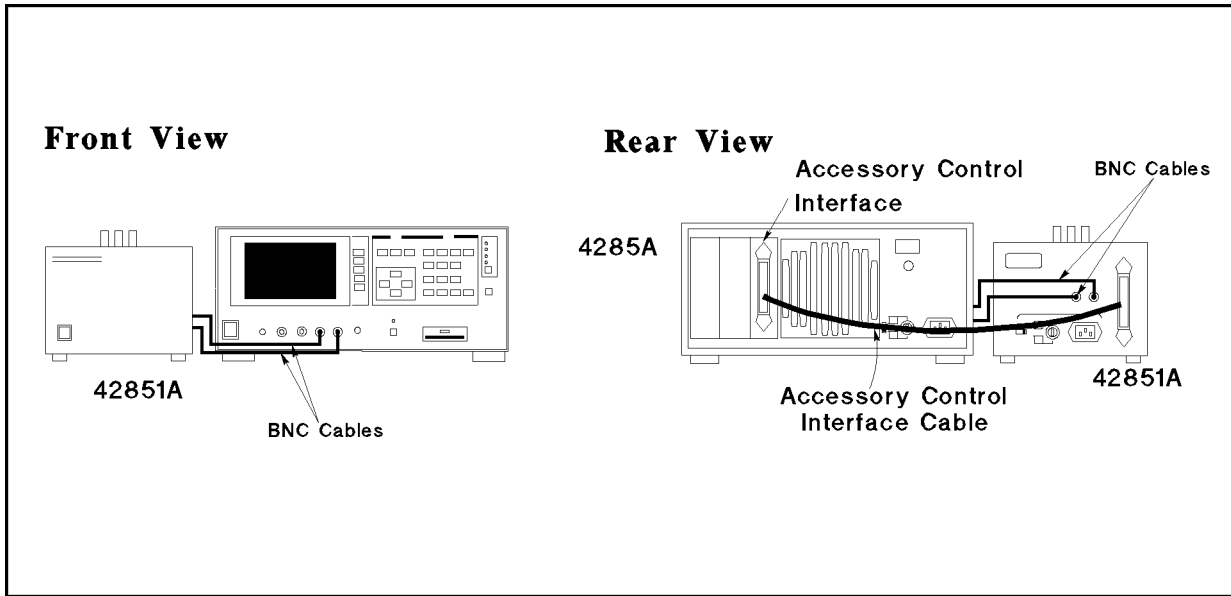

Figure 3-26. Precision Q Measurement Setup

Operation Procedure

1. Turn the 4285A and the 42851A ON.
2. To perform the Precision Q measurement, set the accessory control interface to the Q ADAPTER mode.
 - a. Press **CATALOG/SYSTEM** and **SYSTEM CONFIG**. *SYSTEM CONFIG* page will be displayed
 - b. Move the CURSOR to the *CONFIG* field. **I BIAS**, **Q ADAPTER**, and **OFF** are displayed.
 - c. Press **Q ADAPTER** to perform a precision Q measurement using the resonant measuring method.
3. Setup the 4285A measurement conditions by filling in the fields on the *MEAS DISPLAY* page.
4. Set **FREQ** to 2.52 MHz. (Other functions are left as the default settings.)
 - a. Move the CURSOR to the *FREQ* field. The default measurement frequency, 1.0000 MHz, will be displayed in this field.
 - b. Press **2**, **.**, **5**, and **2**. 2.52 will be displayed on the system message line, and the softkey labels change to the available units **kHz** and **MHz**. Press **MHz**. 2.5200MHz will be displayed on the *FREQ* field.
5. Perform SHORT correction.

SHORT correction is required to compensate for the residuals of the 42851A internal circuit and the BNC coaxial cables. Connect the shorting bar furnished to the 42851A between HIGH and LOW terminals of the 42851A as shown in Figure 3-27.

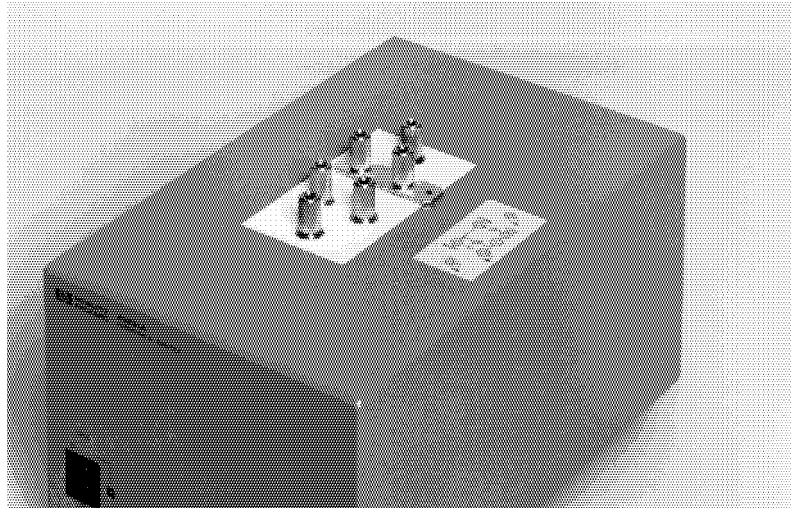

Figure 3-27. Connecting a Shorting Bar

- a. Press **MEAS SETUP** and **CORRECTION**. The *Q CORRECTION* page will be displayed.
 - b. Move the CURSOR to the *SHORT* field. **ON**, **OFF**, and **MEAS SHORT** are displayed.
 - c. Press **MEAS SHORT** to perform the SHORT correction data measurement. *SHORT measurement in progress* will be displayed in the system message line. Wait approximately 20 seconds until the message *SHORT measurement completed* will be displayed on the system message line.
 - d. Press **ON** to set the SHORT correction function to ON.
6. Connect the SMD Test Fixture (42851A Option 001) to the *HIGH* and *LOW* binding post measurement terminal of the 42851A as shown in Figure 3-28.

Note



Residual impedance and stray capacitance of the SMD Test Fixture can be reduced by using the OFFSET L,C,R function on the *Q MEAS SETUP* page. For details of the offset values for the SMD Test Fixture, refer to *42851A Operation Manual* (Agilent Part Number 42851-90000).

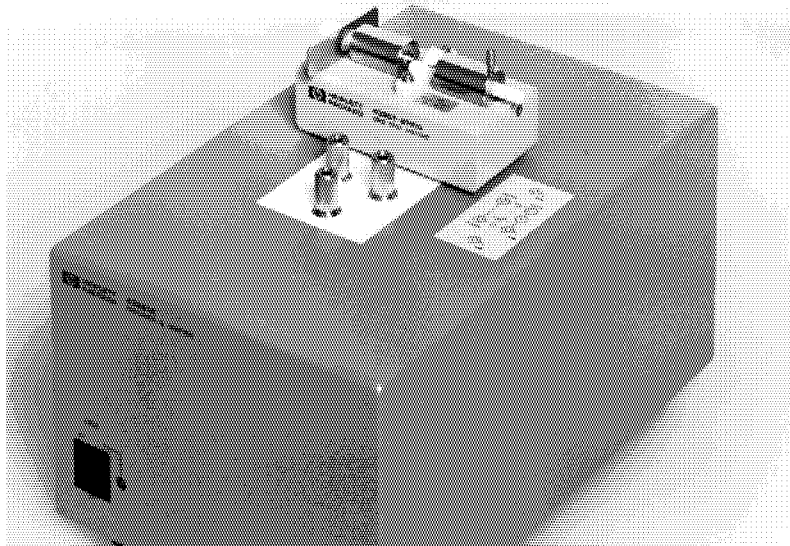

Figure 3-28. Connecting the SMD Test Fixture

7. Connect the DUT to the SMD Test Fixture as shown in Figure 3-29.

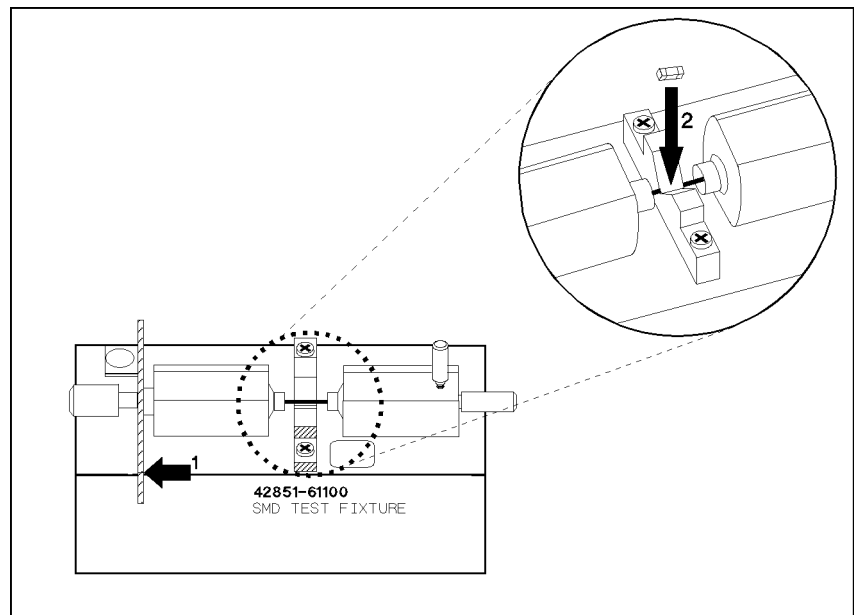

Figure 3-29. Connecting DUT to the SMD Test Fixture

8. Perform the measurement.

Press **[DISP FORMAT]** and **[TRIGGER]**. The 42851A will make a small buzzing sound during the automatic tuning operation, and Q and L values of the chip inductor are displayed in large characters as shown in Figure 3-30. If the 42851A doesn't stop the tuning operation, try changing the measurement frequency, or check to see if the DUT is properly connected to the *HIGH* and *LOW* terminals, or check the cable connection.

If the 4285A does not display the measurement data, check that the TRIGger mode is set to MANual.

```
<Q MEAS DISPLAY>          SYS MENU
FUNC: DIRECT      RANGE:   Q-L
FREQ:  2.5200MHz  BIAS :   150 mV
TUNE:  AUTO       AVG  :    1

      Q   :      3 6 . 4 1

      L   :      1 0 . 1 4 0 0 u H

TUNING C:  392.9pF   V:  114.9mV
CORRECT  :  SHORT
```

Figure 3-30. Inductor Precise Q Measurement Results

Instrument Feature Tutorial

This chapter gives tutorials on how to use the following the features and options of the 4285A Precision LCR Meter.

- Memory Function
- Automatic Level Control Function
- List Sweep
- Printing

Memory Function

The memory function of the 4285A consists of the following two types.

- System memory
- Internal non-volatile memory/external memory card

System Memory

This memory stores control settings which depend upon the individual LCR meters. Such as:

- Control settings on the *CORRECTION* page.
 - OPEN, SHORT, LOAD correction of ON/OFF state
 - OPEN, SHORT correction data for all test frequencies.
 - OPEN, SHORT, LOAD correction data from FREQ1 to FREQ7. (OPEN and SHORT correction data at specified frequencies, and LOAD correction reference data and actual data at specified frequencies.)
- Control settings on the *SYSTEM CONFIG* page.
 - Beeper ON/OFF state
 - GPIB address
 - Talk Only ON/OFF state
 - Accessory I/F Configuration (I BIAS, Q ADAPTER, or OFF)
 - Handler I/F ON/OFF state
 - Scanner I/F ON/OFF state

This memory is non-volatile and is automatically updated when the above settings are changed.

Internal Non-Volatile Memory/External Memory Card

The 4285A allows you to load/store the instrument control settings from/to the internal non-volatile memory or an external memory card (non-volatile). The 4285A stores the following control settings, measurement mode, and display format.

- Display page format when the record stored
- Comment Line
(Same to the comment displayed in the *CATALOG* page)
- Control settings on the *MEAS SETUP* page
- Control settings on the *LIMIT TABLE* page
- Control setting on the *BIN COUNT DISPLAY* page
- Control settings on the *LIST SWEEP SETUP* page

Note



DC BIAS ON/OFF condition on the front panel cannot be stored in a non-volatile memory. If the instrument control settings are loaded from the internal non-volatile memory or the external memory card, the DC bias is automatically turned off for the operator's safety.

The setups above are stored into one record, an object in memory. Up to 10 different records are available on the internal non-volatile memory, and another 10 records are available on the memory card. Records are identified by number. When a record is stored in the internal non-volatile memory, the record number can be set from 0 to 9. When the record is stored in the external memory card, record numbers from 10 to 19 can be set.

When the 4285A is turned on with the memory card inserted into the MEMORY card slot, the 4285A's Auto Load function will load the control settings stored in record number 10. If there are no control settings stored in record number 10 or the stored configuration mode (Normal LCR, I Bias, or Precision Q) is different from the current configuration mode, the power-on default settings will be used.

Perform the following steps to store the control settings to memory.

1. Move the CURSOR to the *SYS MENU* field.
2. If you want to store the data to the memory card, insert a memory card in the MEMORY card slot until it locks into place.
3. Press **STORE**. The message *Enter record number to STORE* will be displayed on the system message line.
4. Enter the record number using the numeric keypad and **ENTER** to store the current control settings. The message *Storing ...* will be displayed on the system message line while writing.

Perform the following steps to load the control settings from memory.

1. Move the CURSOR to the *SYS MENU* field.
2. If you want to load the data from the memory card, insert the memory card into the MEMORY card slot.
3. Press **LOAD**. The message *Enter record number to LOAD* will be displayed on the system message line.
4. Enter the record number you want to load using the numeric entry keys and **ENTER**.

Automatic Level Control Function

Test signal level is a very important factor when evaluating the device under test (DUT). The 4285A can specify the test signal voltage or current. However, the specified voltage value and current value can be obtained when the oscillator output terminal (H_c terminal) is opened or shorted. So the actual test signal level applied to the DUT varies depending on the ratio of the oscillator output impedance and the DUT's impedance.

To avoid this problem, the 4285A employs the Automatic Level Control (ALC) function. ALC function digitally controls the test signal level applied across the DUT without the need for an external computer.

ALC Theory of Operation

The ALC operation is achieved using feedback control loop with the level monitor function as shown in Figure 4-1.

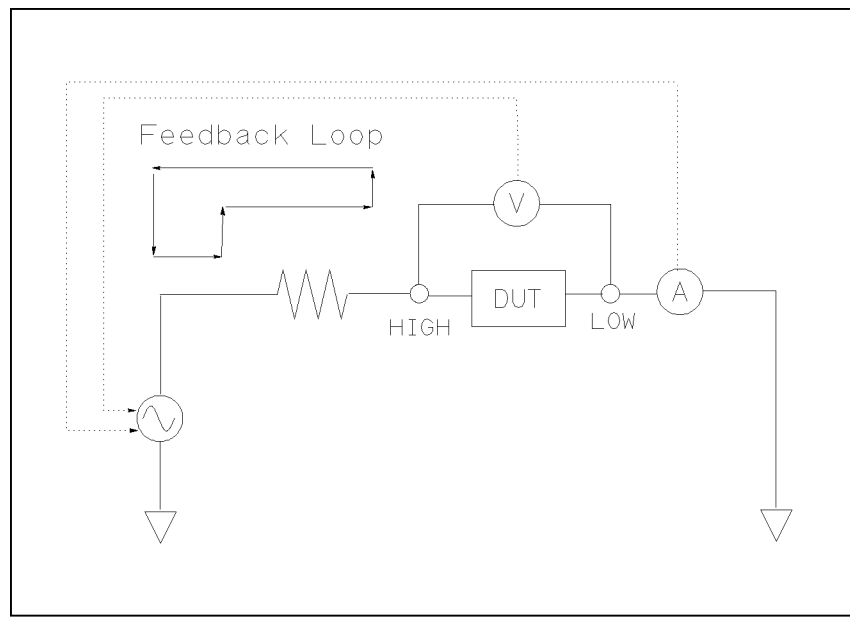

Figure 4-1. Feedback Control Circuit

The feedback operation performs a level measurement/OSC level adjustment 2 to 6 times per measurement. (The required time depends on the device being tested. The more non-linear the device is, the greater the time required.) When the ALC function can't regulate the level within 6 output level measurement/adjustment cycles (when a device has non-linear characteristics, the ALC function may stop before the 6th output level measurement/adjustment cycle if the difference between the selected and actual values is too great), the ALC function stops, and a warning message ALC unable to regulate will be displayed, and sets the oscillator level equal to setting value you select, open-loop, the output level will be the same as when ALC is set to OFF.

ALC Measurement Time

The required time for the the ALC operation is calculated using the following formula.

$$(\text{meas. time (SHORT)} + \text{approx. 115 msec.}) \times n$$

Where,

n: Actual measurement/adjustment cycle
($2 \leq n \leq 6$)

ALC Voltage/Current Setting Range

When the ALC function is active, the test signal level setting range is limited as follows.

Voltage Level: 10 mV_{rms} to 1V_{rms}

Current Level: 100 μA_{rms} to 20 mA_{rms}

Note



If the test signal level setting value exceeds the above limits while the ALC function is active, the ALC function is automatically set to OFF and the entered value is set as a normal test signal level. On the other hand, if the ALC function has been already turned on when the LEVEL setting is out of the ALC's available range, the LEVEL setting is automatically changed to be within the ALC's available range.

Operation Procedure of the ALC Function

Perform the following steps to set the automatic level control function ON or OFF.

1. Press **MEAS SETUP** to display the *MEAS SETUP* page.
2. Move the CURSOR to the *ALC* field. The following softkeys will be displayed.
 - **ON**
 - **OFF**
3. Press **ON** to set the automatic level control function to ON. Press **OFF** to set the automatic level control function OFF.

List Sweep Function

Impedance characteristics evaluation by varying the test condition is very common. To simplify these evaluations and to increase measurement efficiency, the 4285A is equipped with a LIST SWEEP function. The LIST SWEEP function allows you to measure up to 10 parameter points automatically without using an external controller. The following parameters can be used for the LIST SWEEP function.

- Test frequency
- Test signal level (Voltage or Current)
- DC bias level (Voltage¹ or Current²)

¹ : Option 001 DC bias is required

² : Option 002 Accessory control interface, 42841A, and 42842C are required.

The LIST SWEEP function can sweep parameters listed above and the measurement results can be compared to specified limits. These comparison results can be output to the handler interface.

Structure of LIST SWEEP function

The LIST SWEEP function consists of the following two pages.

- *LIST SWEEP DISPLAY* page (under **DISPLAY FORMAT**)
- *LIST SWEEP SETUP* page (under **MEAS SETUP**)

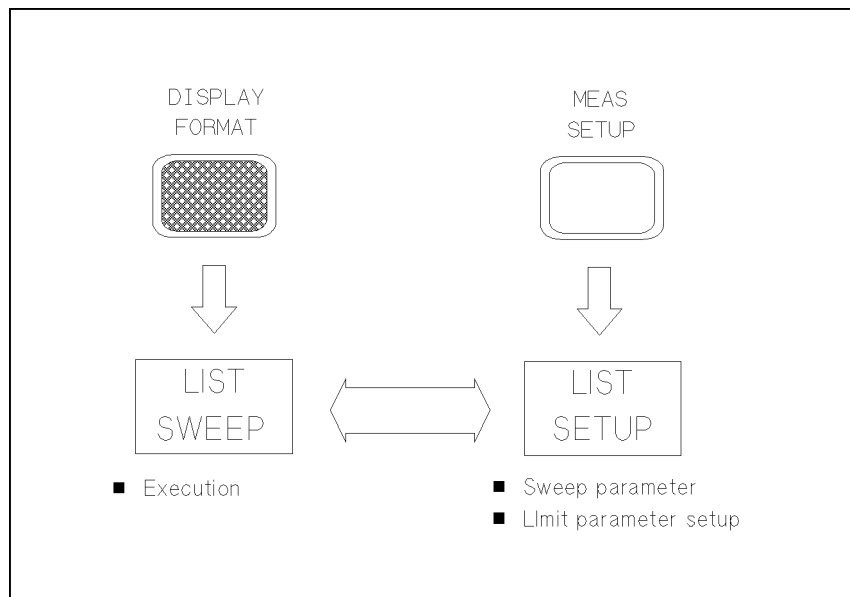

Figure 4-2. Structure of LIST SWEEP Function

LIST SWEEP DISPLAY page

This page is used to perform measurement and to display the measurement and comparison results.

LIST SWEEP SETUP page

This page is used to set the following parameters.

- Sweep mode (*MODE*) for SEQUENTIAL or STEP

- Sweep parameter (*FREQ[Hz]*, *LEVEL[V]*, *LEVEL[A]*, *BIAS[V]*, or *BIAS[A]*)
- Sweep parameter values
- Limit parameter (*LMT*) for data A, data B, or none.
- Limit Values (*LOW*, *HIGH*) for LOW and HIGH or either

Any other measurement condition is as the same to the settings on the *MEAS SETUP* page.

LIST SWEEP Measurement Procedure

This example shows an measurement example under the following measurement conditions.

FUNCTION : *Z-θ*
SWEEP MODE : sequential
SWEEP PARAMETER : frequency [Hz]
SWEEP POINTS : 1 MHz, 2 MHz, 3 MHz, . . . , 9 MHz, 10 MHz
LIMIT PARAMETER : off
Other Settings : Default setting

1. Press **CATALOG/SYSTEM** and **SYSTEM CONFIG**. *SYSTEM CONFIG* page will now be displayed.
2. Move the CURSOR to the *ACCESSORY CONTROL INTERFACE* field. **I BIAS**, **Q ADAPTER**, and **OFF** will be displayed.
3. Press **OFF** to perform the normal LCR measurement.
4. Press **MEAS SETUP**. *MEAS SETUP* page will be displayed.
5. Move the CURSOR to the *FUNC* field.
6. Press more **X/6** until it is changed to more **5/6** and *Z-θ (deg)* is displayed.

Note



Any other measurement conditions set on the *LIST SWEEP SETUP* page are set on the *MEAS SETUP* page and the *CORRECTION* page.

7. Press **Z-θ (deg)** to select the *Z-θ* (degree) measurement function.
8. Press **MEAS SETUP** and **LIST SETUP** to display the *LIST SWEEP SETUP* page.
9. Move the CURSOR to the *MODE* field. The following softkeys will be displayed.
 - **SEQ**
 - **STEP**

The 4285A is equipped with two types of sweep modes, sequential mode (**SEQ**) and step mode (**STEP**). In the case of the sequential mode, the 4285A measures all sweep points each time it is triggered as shown in Figure 4-3.

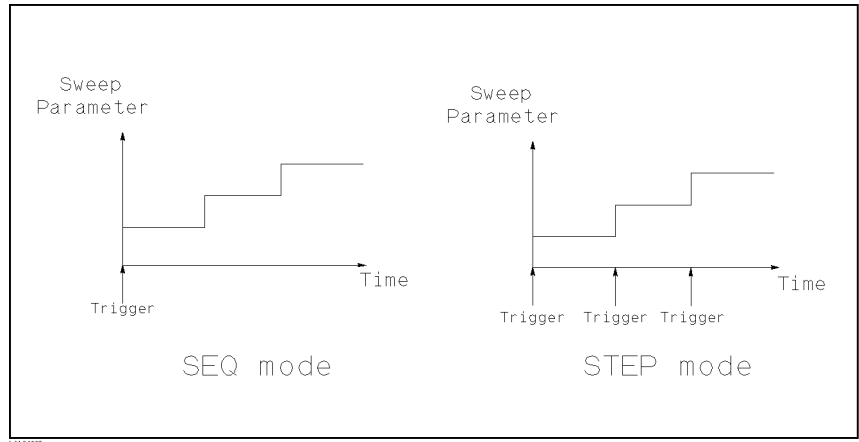

Figure 4-3. List Sweep Modes

In the case of the step mode, the 4285A increments a sweep point each time it is triggered as shown in Figure 4-3.

10. Move the CURSOR to the sweep parameter field. The following softkeys will be displayed.

- *FREQ [Hz]*
- *LEVEL [V]*
- *LEVEL [A]*
- *BIAS [V]*
- *BIAS [A]*

Press **FREQ [Hz]** to choose the frequency as the sweep parameter.

11. Move the CURSOR to the sweep parameter field.
12. Press **(1)** and the unit softkeys will be displayed automatically.
13. Press **MHz**. The CURSOR moves to the *LMT* field, and following softkeys will be displayed.

- **LIMIT DATA A**
This key is used to set the high/low limit for the primary parameter of the measurement function. When this softkey is pressed, the CURSOR moves to the *LOW* field.
- **LIMIT DATA B**
This key is used to set the high/low limit for the secondary parameter of the measurement function. When this softkey is pressed, the CURSOR moves to the *LOW* field.
- **OFF**
This softkey is used to set the list sweep measurement's limit function to OFF for a sweep point. When this softkey is pressed, the CURSOR moves to the next sweep point field.

Press the keys as follows.

OFF
(2), **MHz**, **OFF**

3, MHz, OFF
4, MHz, OFF
5, MHz, OFF
6, MHz, OFF
7, MHz, OFF
8, MHz, OFF
9, MHz, OFF
1, 0, MHz, OFF

Now, the LIST SWEEP setting is complete.

14. Press **DISPLAY FORMAT** and **LIST SWEEP** to display the measurement results. Sweep points and measurement results will be displayed in tabular format and updated continuously.

Print Function

The 4285A can directly print out the data on an GPIB printer without the need for an external computer. Before printing, the 4285A must be set to the talk only mode. Press **CATALOG/SYSTEM** and **SYSTEM CONFIG** to display *SYSTEM CONFIG* page.

To set the 4285A to the talk-only mode, move the CURSOR to the *TALK ONLY* field, and press **ON**. When the *TALK ONLY* field is set to ON, talk (TLK) GPIB state indicator on the front panel is lit.

Print Mode

The 4285A has the following two print modes.

- **PRINT DISP**
- **PRINT DATA**

PRINT DISP dumps the information to the printer currently displayed on the LCD panel except for softkey labels.

PRINT DATA continuously outputs the measurement result, status, and comparison result (if required) to the printer.

PRINT DISP, **PRINT DATA** capabilities are available in the following pages.

Table 4-1. PRINT DISP and PRINT DATA Availability

| Page Name | PRINT DISP | PRINT DATA |
|--|------------|------------|
| <i>MEAS DISPLAY</i> ¹ | ✓ | ✓ |
| <i>BIN No. DISPLAY</i> ¹ | ✓ | ✓ |
| <i>BIN COUNT DISPLAY</i> ¹ | ✓ | ✓ |
| <i>LIST SWEEP DISPLAY</i> ¹ | ✓ | ✓ |
| <i>MEAS SETUP</i> ¹ | ✓ | |
| <i>CORRECTION</i> ¹ | ✓ | |
| <i>LIMIT TABLE SETUP</i> ¹ | ✓ | |
| <i>LIST SWEEP SETUP</i> ¹ | ✓ | |
| <i>CATALOG</i> | ✓ | |
| <i>SYSTEM CONFIG</i> | ✓ | |
| <i>CABLE CORRECTION</i> | | |
| <i>SELF TEST</i> | | |
| <i>Q MEAS DISPLAY</i> ² | ✓ | ✓ |
| <i>Q BIN No. DISPLAY</i> ² | ✓ | ✓ |
| <i>Q BIN COUNT DISPLAY</i> ² | ✓ | ✓ |
| <i>Q LIST SWEEP DISPLAY</i> ² | ✓ | ✓ |
| <i>Q MEAS SETUP</i> ² | ✓ | |
| <i>Q CORRECTION</i> ² | ✓ | |
| <i>Q LIMIT TABLE SETUP</i> ² | ✓ | |
| <i>Q LIST SWEEP SETUP</i> ² | ✓ | |

1 Normal LCR measurement mode or high current DC biased measurement mode only.

2 Precision Q measurement mode only.

Printer Requirements

To correctly print the data, the printer must be capable of the following.

- GPIB Interface
- Listen Always (only) state

For example, 2225 ThinkJet Printer (with GPIB interface) matches these requirements.

Printer Troubleshooting

If you encounter a printing problem, check the following.

1. Look for an error message on the LCD panel. (All error messages are explained in *Appendix B* of the *4285A operation manual* (Agilent part number 04285-90000).
2. Make sure the printer is plugged in, turned on, connected to the 4285A, and loaded with paper.
3. Make sure the printer is set to the listen always state.

Note



Some printers read the switch settings only when they are first turned on. Therefore if you change any of the switch settings, you must turn the printer off for several seconds and back on before printing.

4. Make sure the 4285A is in the talk only mode. Check that the talk (TLK) GPIB status indicator on the front panel is lit.
5. Replace the GPIB cable.
6. Substitute a different printer.

What's Next?

Now that you have the instrument unpacked, inspected and operating, and you will also be familiar with the 4285A's basic operation. Your next step depends on your needs.

If you want to perform normal LCR measurement (auto balancing bridge measuring method), refer to *4285A OPERATION MANUAL* (Agilent Part Number 04285-90010). This manual provides general information, specifications, front panel operation, GPIB programming information, and in depth reference information.

If you want to perform precision Q measurement by the resonant method with the 42851A, refer to *42851A OPERATION MANUAL* (Agilent Part Number 42851-90010). This manual provides general information, specifications, front panel operation, GPIB programming information, and in depth reference information.

If you want to perform the high DC current biased measurement by combining with the 42841A and 42842C, refer to *42841A OPERATION MANUAL* (Agilent Part Number 42841-90010) or *4285A OPERATION MANUAL* (Agilent Part Number 04285-90010). *42841A OPERATION MANUAL* provides general information, specifications, operation procedure combining the 4285A with the 42841A, and additional or modified GPIB commands. The *4285A OPERATION MANUAL* provides the error and system messages.

